

Jamato[®]

INDUSTRIAL SEWING MACHINE

**ILLUSTRATED SPARE PARTS LIST
FOR
BLIND STITCH MACHINE**

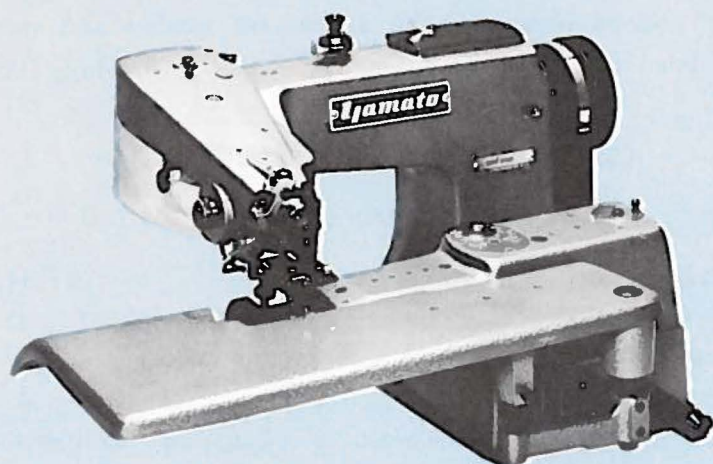

MODELS & DEVICES

CM-251	CM-252	CM-255	CM-256	CM-257
CM-258	CM-259	CM-260	CM-261	CM-262
CM-263	CM-265	CM-270		

T AT AL2

Guideline for Utilization of the Parts Book-

Quickly and exactly you will obtain the right object in your hand, by this Parts Book, when certain part of the machines is necessary for replacement or the modification. Because this Parts Book is printed showing all of part-names in contrast with their illustrations by each mechanism.

Contents of the Book are for CM-251 the standard model from Page 1 to 9 and for sub-models and attachments from Page 10 to 22.

Note:* Parts for sub-models are shown only by those different from the standard models.

* Parts in common use with the standard models are not shown except those of virtual lines (two-dots chain lines).

As for Gauge Parts, they are shown in the "List of Main Spare Parts", Page 23, for your convenience.

By Part Numbers in "INDEX" from Page 24, you can easily check shape of the part and /or its setting place on machines.

When you will order the part, it must be placed by the number. Take note please.

Additionally, we beg your kind understanding for the fact that there may be some differences in numbers or shapes owing to the successive studies and improvements, because this Parts Book has been made on the basis of production in May, 1982.

〈パーツブックご利用に際して〉

この度は、ヤマトCM-251クラスのマシンをお買上げ頂き、誠にありがとうございます。

このパーツブックは修理交換用の部品や他のモデルに改造する場合等に目的の部品をいち早く捜して頂くため、分かり易く機構別にイラストと表を対比して掲載しております。

すなわち、CM-251を基本モデルとし、1ページから9ページまでを基本モデル、10ページからサブモデル及び附帯装置の部品を掲載しております。このサブモデルの部品構成は、基本モデルと異なる部品のみを掲載しており、仮想線（2点鎖線）及び無掲載の部品は基本モデルと共通使用のものでありますから、この点ご注意ください。

ゲージパーツ関係は23ページに主要部品リストとして分かり易く表にしてありますので合わせてご利用ください。

また、部品番号で部品の形状や、マシンのどの部分に組込まれている部品か等をお調べの場合は24ページからの索引(INDEX)にて簡単に引き出せます。

部品をお求めの際は部品番号でお間違いのないようお願いいたします。

なお、このパーツブックは1982年5月現在製造中のマシンを基本に作成しております。品質性能に関しましては絶えず研究し、日々改良を加えておりますので部品番号及び形状等が異なる場合がありますからご了承ください。

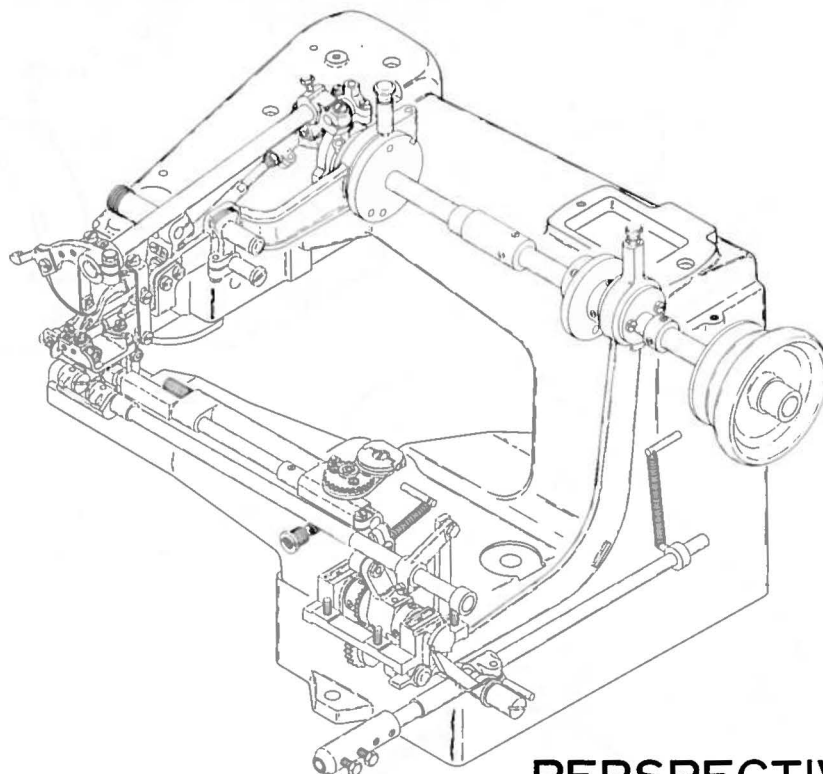

PERSPECTIVE
透視図

CONTENTS

目次

MISCELLANEOUS COVERS	カバー関係.....	1
THREAD EYELETS, BUSHINGS & OILING SPOTS.....	糸道、ブッシュ及び注油関係.....	2
NEEDLE DRIVING MECHANISM	針振り機構.....	3
PRESSER FOOT MECHANISM (1)	押工機構(1).....	4
" " " (2)	" (2).....	5
RIDGE FORMING MECHANISM (1)	突上げ機構(1).....	6
" " " (2)	" (2).....	7
LOOPER DRIVING MECHANISM.....	ルーバ機構.....	8
FEED DRIVING MECHANISM.....	送り機構.....	9
CM-252 EXCLUSIVE PARTS	サブモデル専用部品.....	10
CM-255, -256 EXCLUSIVE PARTS	サブモデル専用部品.....	11
CM-257, -258 EXCLUSIVE PARTS	サブモデル専用部品.....	12
CM-259 EXCLUSIVE PARTS	サブモデル専用部品.....	13
CM-260 EXCLUSIVE PARTS	サブモデル専用部品.....	14
CM-261, -265 EXCLUSIVE PARTS	サブモデル専用部品.....	15
CM-262 EXCLUSIVE PARTS	サブモデル専用部品.....	16
CM-263 EXCLUSIVE PARTS (1)	サブモデル専用部品(1).....	17
" " " (2)	" " (2).....	18
CM-270 EXCLUSIVE PARTS (1)	サブモデル専用部品(1).....	19
(2)	" " (2).....	20
"T" & "AT" DEVICE	"T"及び"AT"装置.....	21
"AL2" DEVICE & THREAD STAND	"AL2"装置及び糸立台.....	22
LIST OF MAIN SPARE PARTS.....	主要部品リスト.....	23
INDEX	索引.....	24

※Illustration of this Parts Book is based on the Model CM-251.

このパーツブックはCM-251を基本モデルにしてイラストを作成しております。

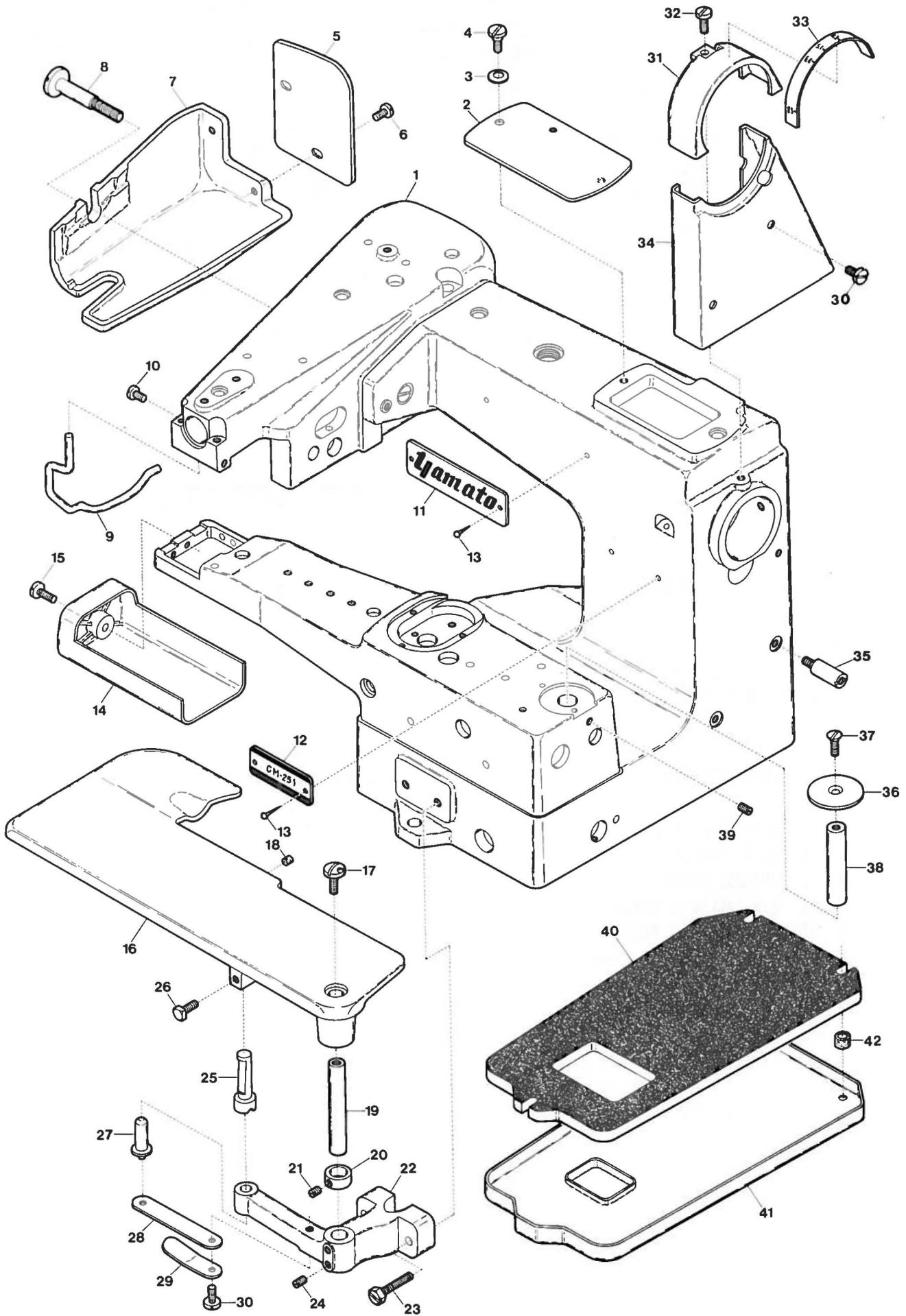

Ref. No.	Parts No.	Description	品名	Amt. Req.
1	80140	Machine Frame	アームベッド	1
2	80746	Top Cover	上蓋	1
3	559	Spring Washer for 80746	スプリングワッシャー	1
4	6147	Screw for 80746	上蓋止ネジ	1
5	80144	Head Cover (Rear)	ヘッドカバー(後)	1
6	4475	Screw for 80144	ヘッドカバー(後)止ネジ	2
7	80295	Head Cover	ヘッドカバー	1
8	6869	Screw for 80295	ヘッドカバー止ネジ	1
9	80146	Finger Guard	フィンガーガード	1
10	1196	Screw for 80146	フィンガーガード止ネジ	1
11	937	Brand Name Plate	銘板	1
12		Model Plate (See the table.)	型式板(下表参照)	1
13	721	Rivet for 937, Model Plate	止メ鎮	4
14	80115	Cylinder Cover	腕カバー	1
15	4481	Screw for 80115	腕カバー止ネジ	1
16	80124	Cloth Plate	クロスプレート	1
17	4641	Screw for 80124	クロスプレート止ネジ	1
18	20072	Cloth Plate Rubber Cushion	埋メ座	1
19	80122	Cloth Plate Hinge Pin	クロスプレートヒンジピン	1
20	80123	Cloth Plate Hinge Pin Collar	クロスプレートヒンジピンカラー	1
21	3554	Screw for 80123	ヒンジピンカラー止ネジ	1
22	80121	Cloth Plate Hinge	クロスプレートヒンジ	1
23	5566	Screw for 80121	クロスプレートヒンジ止ネジ	2
24	3642	Screw for 80122	ヒンジピン止ネジ	2
25	80125	Cloth Plate Latch Pin	クロスプレートストップピン	1
26	5662	Screw for 80125	クロスプレートストップピン止ネジ	1
27	80126	Cloth Plate Spring Pin	飛ビ込ミピン	1
28	80127	Cloth Plate Spring (Large)	クロスプレートスプリング(大)	1
29	80128	Cloth Plate Spring (Small)	クロスプレートスプリング(小)	1
30	4551	Screw for 80128, 80297	止ネジ	3
31	80293	Belt Cover (Upper)	ベルトカバー(上)	1
32	4555	Screw for 80293	ベルトカバー(上)止ネジ	1
33	80118	Pulley Graduations Plate	プーリ目盛板	1
34	80297	Belt Cover (Lower)	ベルトカバー(下)	1
35	3570	Screw for 80297	ベルトカバー(下)支エネジ	2
36	81608	Stop Pin Cover	制限ピンカバー	1
37	5347	Screw for 81608	制限ピンカバー止ネジ	1
38	81607	Stop Pin for Ridge Forming Shaft	制限ピン	1
39	3556	Screw for 81607	制限ピン止ネジ	1
40	80154	Felt Pad	フェルトパッド	1
41	80155	Oil Reciever	油受ケ	1
42	80153	Oil Reciever Seal	シール座	3

MODEL PLATE

Models	Parts No.	Models	Parts No.	Models	Parts No.	Models	Parts No.
CM-251	81200	CM-258	81205	CM-262/T	81213	CM-263/AT	81216
-252	81201	-259	81206	-262/AT	81215	-263/AT/AL2	81219
-255	81202	-260	81217	-262/AT/AL2	81218	-265	81211
-256	81203	-261	81207	-263	81209	-270	81212
-257	81204	-262	81208	-263/T	81214		

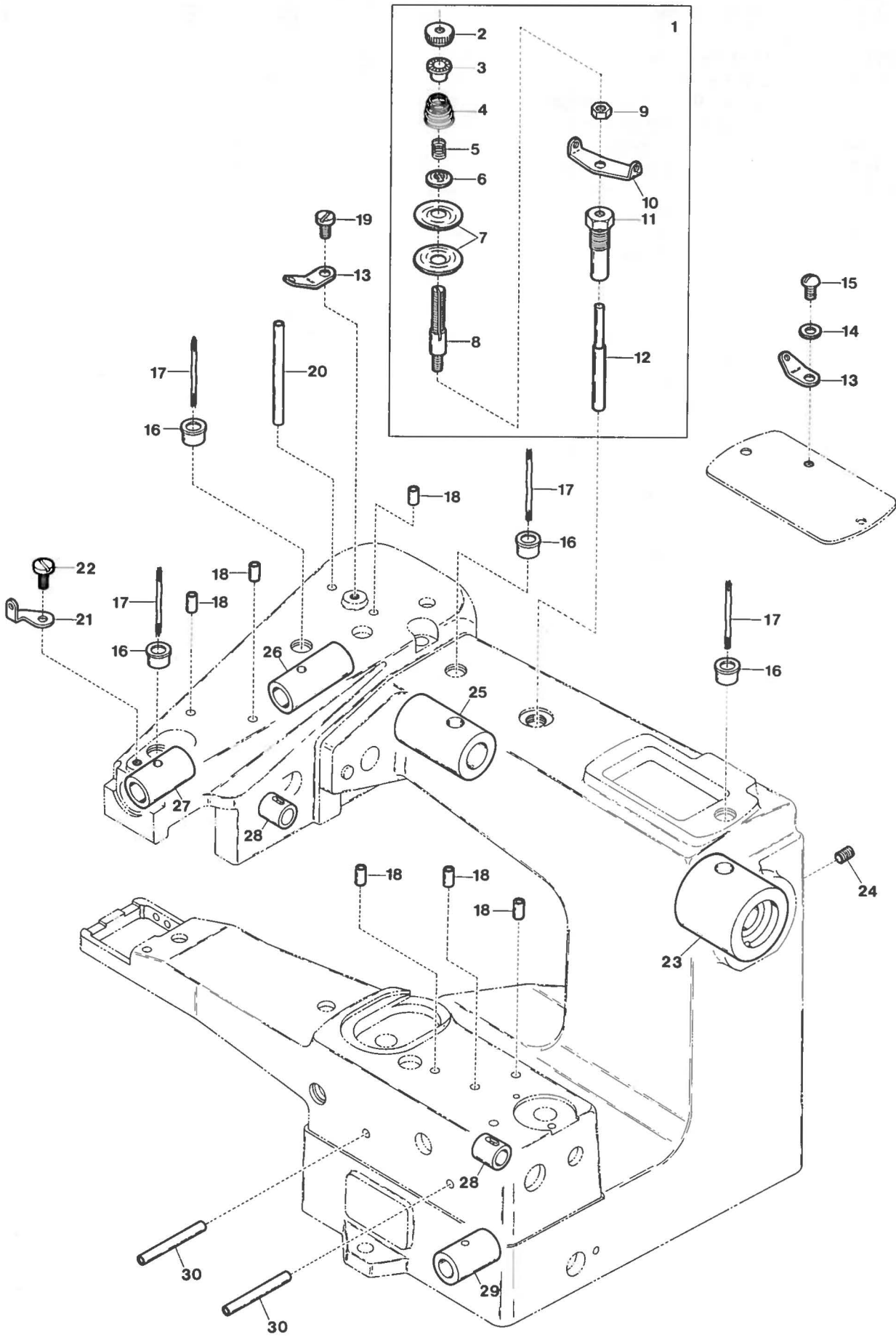

Ref. No.	Parts No.	Description	品名	Amt. Req.
1	80740	Thread Tension Mechanism, Complete Set	糸調子器(組)	1
2	182	Thread Tansion Spring Nut	糸調子ナット	1
3	20126	Tension Spring Bushing	糸調子ナット回り止メ	1
4	85277	Thread Tension Spring	糸調子バネ	1
5	80744	Thread Nipper Spring	糸挟ミバネ	1
6	80743	Thread Nipper Spring Holder	糸挟ミバネ受ケ	1
7	31111	Tension Disc	糸調子皿	2
8	6560	Tension Post	糸調子棒	1
9	364	Nut for 6560	ナット	1
10	80745	Tension Disc Eyelet	調子台糸道	1
11	80741	Tension Post Support	糸調子台	1
12	80742	Tension Release Pin	糸緩メ押し棒	1
13	33764	Thread Eyelet	糸道	2
14	532	Washer for 33764	ワッシャ	1
15	1330	Screw for 33764	糸道止ネジ	1
16	80131	Oil Cup	注油口金	4
17		Oil Wick for 80131	油芯	4
18	80132	Oil Tube (7.9mm)	注油管(7.9mm)	6
19	4474	Screw for 33764	糸道止ネジ	1
20	80136	Oil Tube (53.2mm)	注油管(53.2mm)	1
21	80393	Thread Eyelet (Front)	前糸道	1
22	4471	Screw for 80393	前糸道止ネジ	2
23	80200	Main Shaft Bushing (Right)	大ブッシュ	1
24	3643	Screw for 80200	大ブッシュ止ネジ	1
25	80204	Main Shaft Bushing (Left)	小ブッシュ	1
26	80220	Needle Driving Shaft Bushing (Rear)	針振り軸ブッシュ(後)	1
27	80221	Needle Driving Shaft Bushing (Front)	針振り軸ブッシュ(前)	1
28	80511	Bushing for 80313, 80508	ブッシュ	2
29	80305	Knee Press Shaft Bushing	膝受ケ軸ブッシュ	1
30	80135	Oil Tube (38.1mm)	注油管(38.1mm)	2

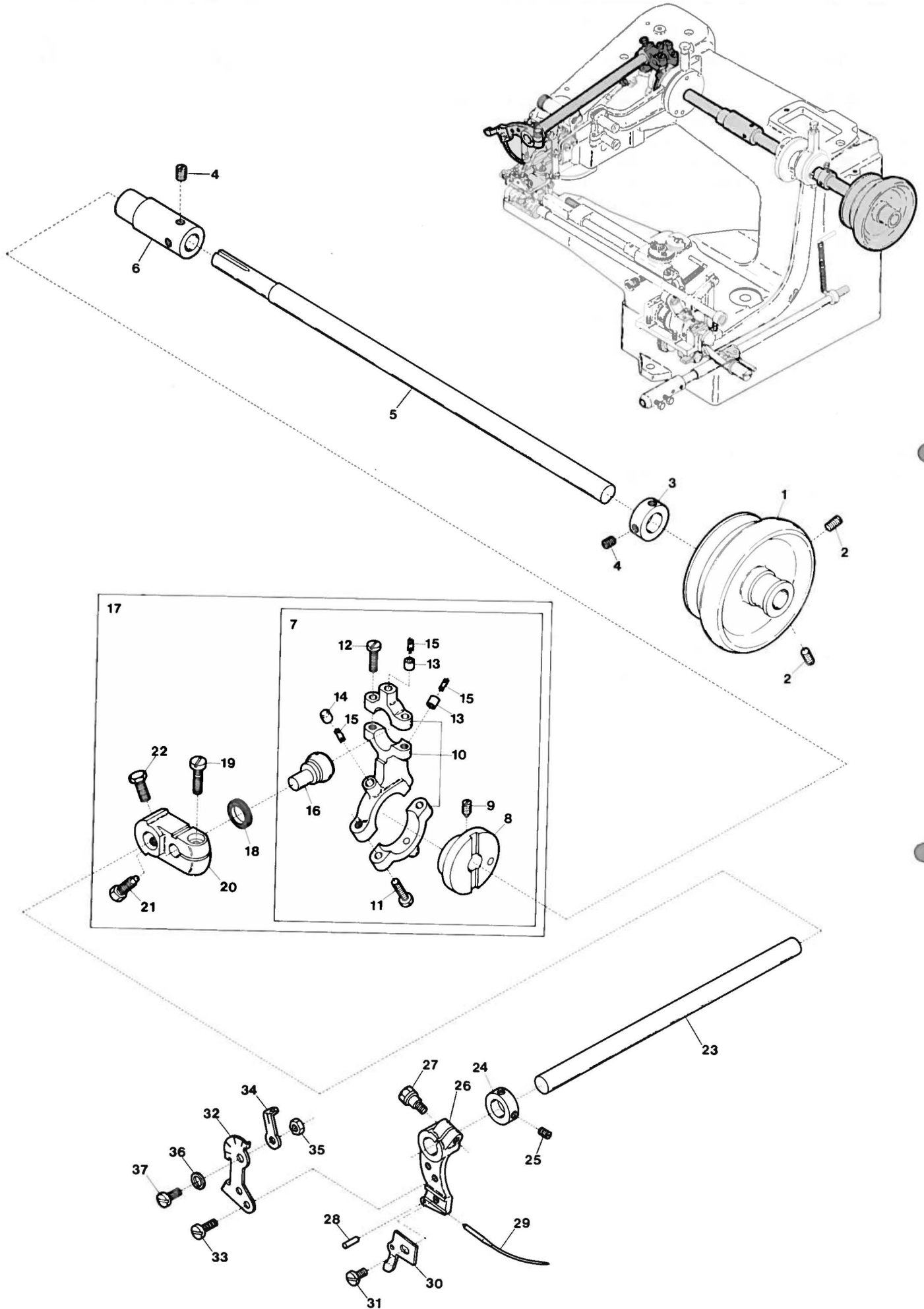

Ref. No.	Parts No.	Description	品名	Amt. Req.
1	80145	Pulley	プーリ	1
2	3595	Screw for 80145	プーリ止ネジ	2
3	80123	Main Shaft Collar	上軸カラー	1
4	3554	Screw for 80123, 80701	止ネジ	4
5	80202	Main Shaft	上軸	1
6	80701	Tension Release Eccentric	糸緩メエキセン	1
7	80209	Needle Driving Eccentric, Complete Set	針振り球エキセン(組)	1
8	80211	Needle Driving Eccentric	針振り球エキセン	1
9	3551	Screw for 80211	針振り球エキセン止ネジ	1
10	80210	Needle Driving Connecting Rod	針振りロッド	1
11	4392	Screw for 80210	針振りロッド止ネジ	2
12	4391	Screw for 80210	針振りロッド止ネジ	2
13	80216	Oil Retainer (with hole)	油溜メ(穴有)	2
14	80215	Oil Retainer (without hole)	油溜メ(穴無)	1
15	—	Oil Wick for 80216, 80215	油芯(毛糸)	3
16	80217	Ball Eccentric	エキセン球	1
17	80208	Needle Driving Shaft Lever, Complete Set	針振り軸腕(組)	1
18	608	Fiber Packing Piece	ファイバーパッキン	1
19	4554	Screw for 80217	エキセン球止ネジ	1
20	80218	Needle Driving Shaft Lever	針振り軸腕	1
21	5553	Screw for 80218	針振り軸腕止ネジ	1
22	5557	Screw for 80218	針振り軸腕止ネジ	1
23	80219	Needle Driving Shaft	針振り軸	1
24	80222	Needle Driving Shaft Collar	針振り軸カラー	1
25	3471	Screw for 80222	針振り軸カラー止ネジ	2
26	80328	Needle Driving Lever	針振り腕	1
27	5549	Screw for 80328	針振り腕止ネジ	1
28	80224	Needle Stop Pin	針当りピン	1
29	—	Needle (System:LW×6T)	針(LW×6T)	1
30	80226	Needle Clamp	針止メ	1
31	4397	Screw for 80226	針止メ止ネジ	1
32	80392	Needle Thread Pull-off Eyelet	針糸繰り糸道	1
33	4358	Screw for 80392	針糸繰り糸道止ネジ	2
34	80391	Needle Thread Pull-off	針糸繰り	1
35	322	Nut for 80391	ナット	1
36	644	Spring Washer for 80391	スプリングワッシャ	1
37	6035	Screw for 80391	針糸繰り止ネジ	1

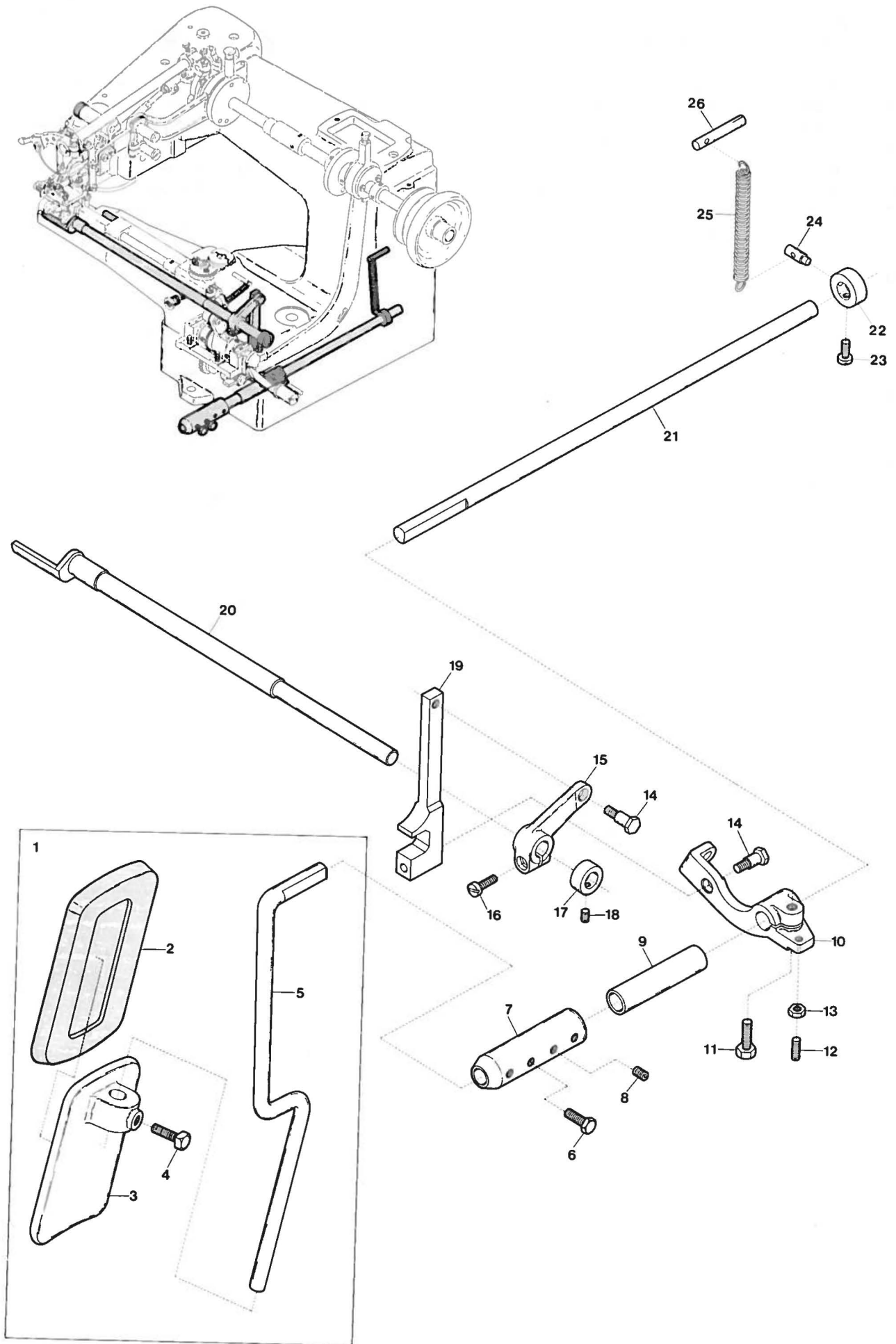

Ref. No.	Parts No.	Description	品名	Amt. Req.
1	80300	Knee Press, Complete Set	膝受ケ(組)	1
2	80299	Knee Press Cushion	膝受ケクッション	1
3	80301	Knee Press	膝受ケ	1
4	5662	Screw for 80301	膝受ケ止ネジ	1
5	80302	Knee Press Shank	膝受ケシャंक	1
6	5555	Screw for 80302	膝受ケシャंक止ネジ	2
7	80303	Knee Press Joint	膝受ケジョイント	1
8	3653	Screw for 80303	膝受ケジョイント止ネジ	2
9	80306	Knee Press Shaft Sleeve	膝受ケ軸スリーブ	1
10	80310	Knee Press Shaft Lever	膝受ケ軸腕	1
11	5565	Screw for 80310	膝受ケ軸腕止ネジ	1
12	3394	Adjusting Screw for 80663	回り止メ調節ネジ	1
13	339	Locking Nut for 3394	ロックナット	1
14	6047	Screw for 80311	押工軸リンク止ネジ	2
15	80312	Presser Foot Depress Shaft Lever	押工軸腕	1
16	4552	Screw for 80312	押工軸腕止ネジ	1
17	80314	Presser Foot Depress Shaft Collar	押工軸カラー	1
18	3393	Screw for 80314	押工軸カラー止ネジ	1
19	80311	Presser Foot Connecting Link	押工軸リンク	1
20	80313	Presser Foot Depress Shaft	押工軸	1
21	80304	Knee Press Shaft	膝受ケ軸	1
22	80308	Knee Press Shaft Collar	膝受ケ軸カラー	1
23	4397	Screw for 80308	膝受ケ軸カラー止ネジ	1
24	724	Pin for 80309	バネ掛ケピン	1
25	80309	Knee Press Shaft Spring	膝受ケ軸バネ	1
26	80325	Spring Pin	膝受ケ軸バネ掛ケ	1

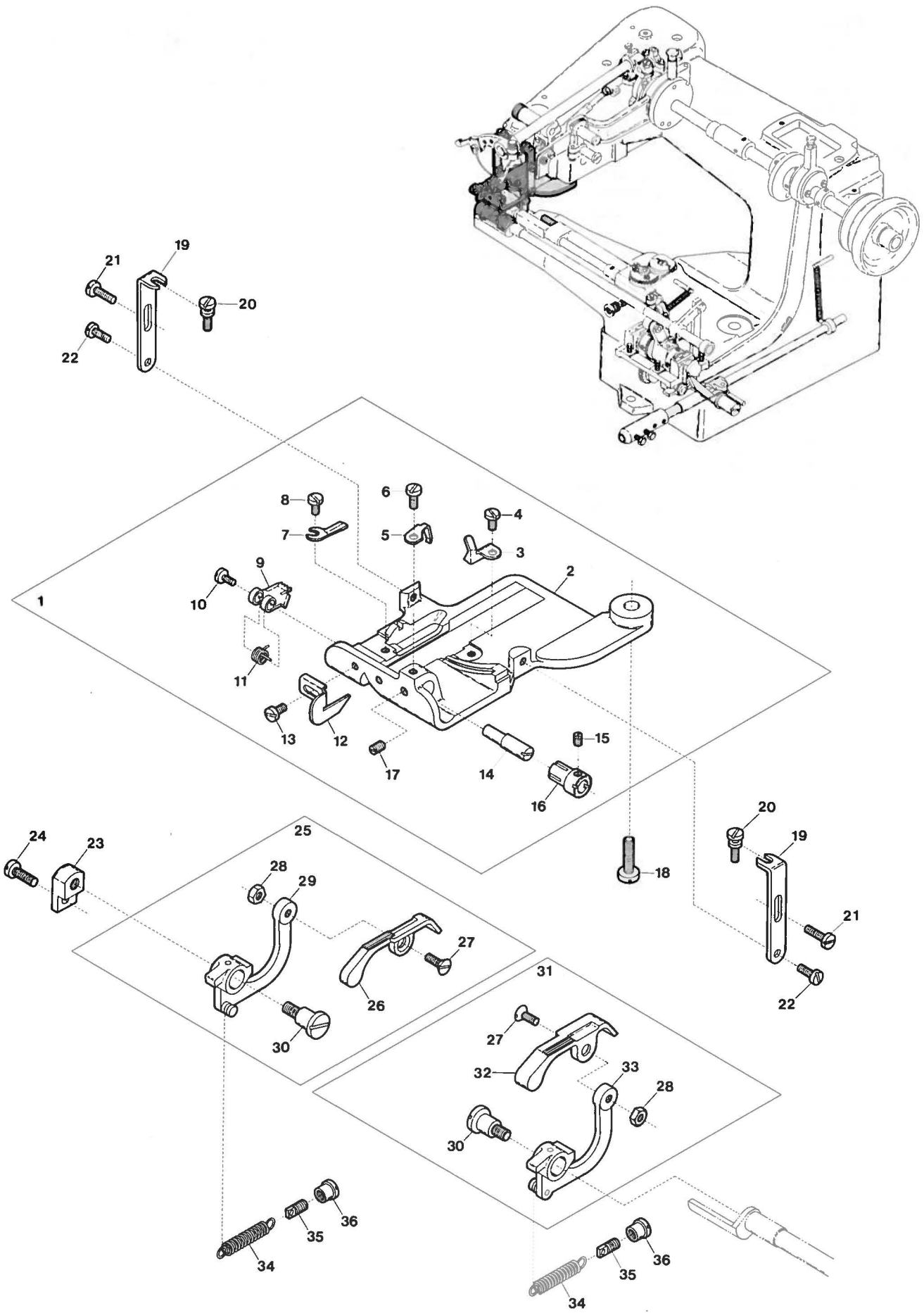

<u>Ref. No.</u>	<u>Parts No.</u>	<u>Description</u>	<u>品 名</u>	<u>Amt. Req.</u>
1	80290	Presser Foot Plate, Complete Set	押工受ケ(組).....	1
2	80291	Presser Foot Plate	押工受ケ.....	1
3	80418	Chaining Finger	押工受ケツノ.....	1
4	4246	Screw for 80418	押工受ケツノ止ネジ.....	1
5	80357	Cloth Retainer Stopper.....	爪当り.....	1
6	4395	Screw for 80357	爪当り止ネジ.....	1
7	80358	Needle Guard	針受ケ.....	1
8	4393	Screw for 80358	針受ケ止ネジ.....	1
9	81352	Cloth Retainer	爪.....	1
10	4245	Screw for 81352	爪止ネジ.....	1
11	80355	Cloth Retainer Spring.....	爪バネ.....	1
12	81354	Cloth Guide	爪下案内.....	1
13	4283	Screw for 81354	爪下案内止ネジ.....	1
14	80354	Cloth Retainer Adjusting Pin	爪エキセンピン.....	1
15	3312	Screw for 80354	爪エキセンピン止ネジ.....	1
16	80356	Cloth Retainer Adjusting Sleeve	爪バネ調節スリーブ.....	1
17	3393	Screw for 80356	爪バネ調節スリーブ止ネジ.....	1
18	4642	Screw for 80291	押工受ケ止ネジ.....	1
19	80381	Presser Foot Plate Support.....	押工受ケ支工.....	2
20	7420	Adjusting Screw for 80381	押工受ケ支工調節ネジ.....	2
21	4398	Screw for 80381	押工受ケ支工止ネジ.....	2
22	4317	Screw for 80381	押工受ケ支工止ネジ.....	2
23	80316	Presser Foot Lever Holder	押エレバー支工.....	1
24	4481	Screw for 80316	押エレバー支工止ネジ.....	1
25	80323	Presser Foot (Left), Complete Set	押工(左)(組).....	1
26	80317	Presser Foot (Left)	押工(左).....	1
27	6339	Screw for 80317, 80318	押工止ネジ.....	2
28	339	Nut for 80317, 80318	ナット.....	2
29	80321	Presser Foot Lever (Left)	押エレバー(左).....	1
30	6051	Screw for 80321, 80320	押エレバー止ネジ.....	2
31	80322	Presser Foot (Right), Complete Set	押工(右)(組).....	1
32	80318	Presser Foot (Right)	押工(右).....	1
33	80320	Presser Foot Lever (Right)	押エレバー(右).....	1
34	80348	Presser Foot Spring.....	押工バネ.....	2
35	6638	Screw for 80348.....	押工バネ掛ケネジ.....	2
36	239	Adjusting Nut for 80348.....	押工バネ調節ナット.....	2

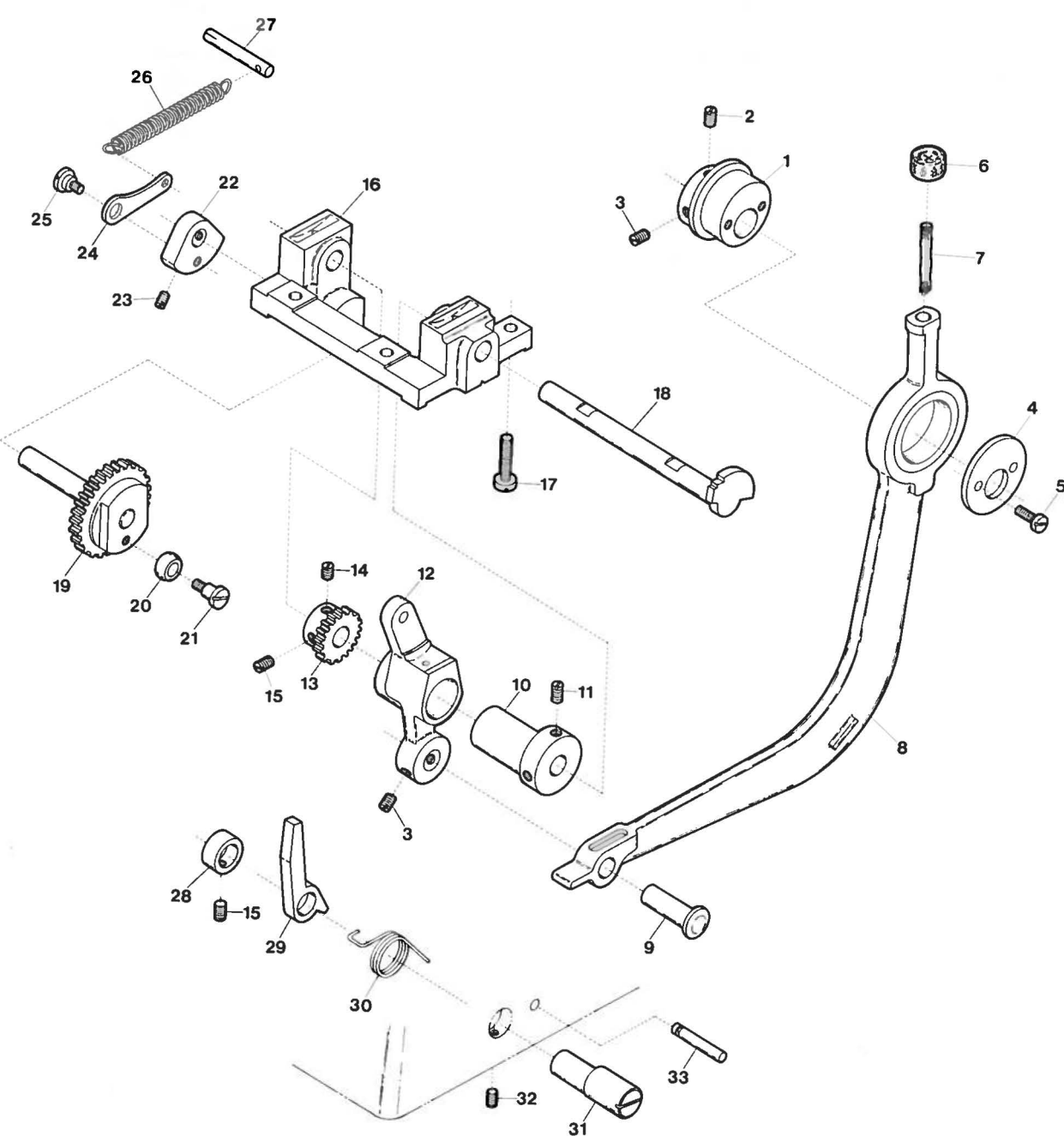
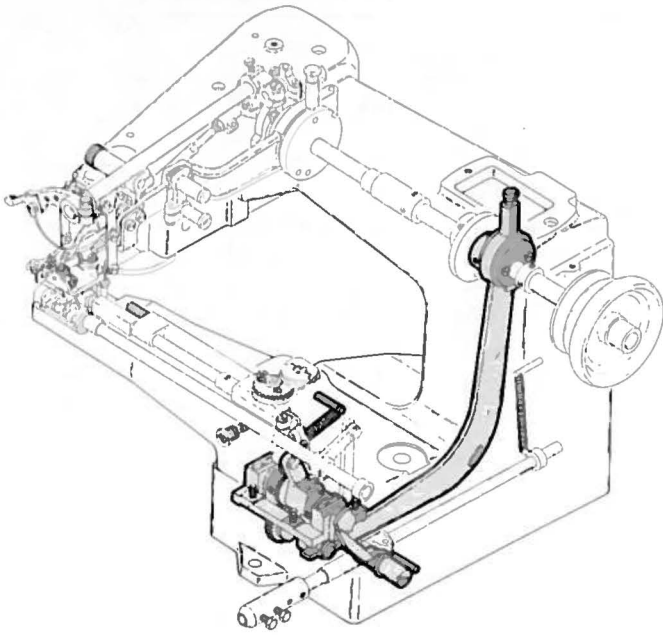

Ref. No.	Parts No.	Description	品名	Amt. Req.
1	81601	Ridge Forming Plate Eccentric	突上げエキセン	1
2	3559	Screw for 81601	突上げエキセン止ネジ	1
3	3555	Screw for 81601, 80605	止ネジ	3
4	81602	Ridge Forming Plate Eccentric Cover	突上げエキセン蓋	1
5	1196	Screw for 81602	突上げエキセン蓋止ネジ	2
6	80619	Oil Cap	オイルキャップ	1
7	—	Oil Wick for 81617	油芯	1
8	81617	Ridge Forming Plate Connecting Rod	突上げロッド	1
9	80605	Ridge Forming Plate Connecting Rod Pin	突上げロッドピン	1
10	80657	Ridge Forming Plate Oscillating Eccentric	突上げクランクエキセン	1
11	3558	Screw for 80657	突上げクランクエキセン止ネジ	2
12	80606	Ridge Forming Plate Oscillating Lever	突上げクランク	1
13	80655	Ridge Forming Plate Gear (Small)	小歯車	1
14	8047	Screw for 80655	小歯車止ネジ	1
15	3554	Screw for 80655, 80662	止ネジ	2
16	80651	Ridge Forming Basement	突上げ装置台	1
17	5061	Screw for 80651	突上げ装置台止ネジ	3
18	80656	Ridge Forming Plate Oscillating Shaft	突上げクランク軸	1
19	80005	Ridge Forming Plate Gear (Large)	大歯車	1
20	80652	Ridge Forming Plate Gear Roller	コロ	1
21	6031	Screw for 80652	コロ止ネジ	1
22	80658	Collar for 80005	大歯車カラー	1
23	3556	Screw for 80658	大歯車カラー止ネジ	2
24	80659	Gear Spring Connecting Link	バネ掛け板	1
25	6048	Screw for 80659	バネ掛け板止ネジ	1
26	80309	Gear Spring	バネ	1
27	80325	Gear Spring Pin	バネ掛けピン	1
28	80662	Collar for 80663	回り止メカラー	1
29	80663	Oscillating Shaft Locking Latch	回り止メ	1
30	80664	Locking Latch Spring	回り止メバネ	1
31	80661	Oscillating Shaft Locking Latch Pin	回り止メピン	1
32	3473	Screw for 80661	回り止メピン止ネジ	1
33	80665	Locking Latch Spring Pin	回り止メバネ掛けピン	1

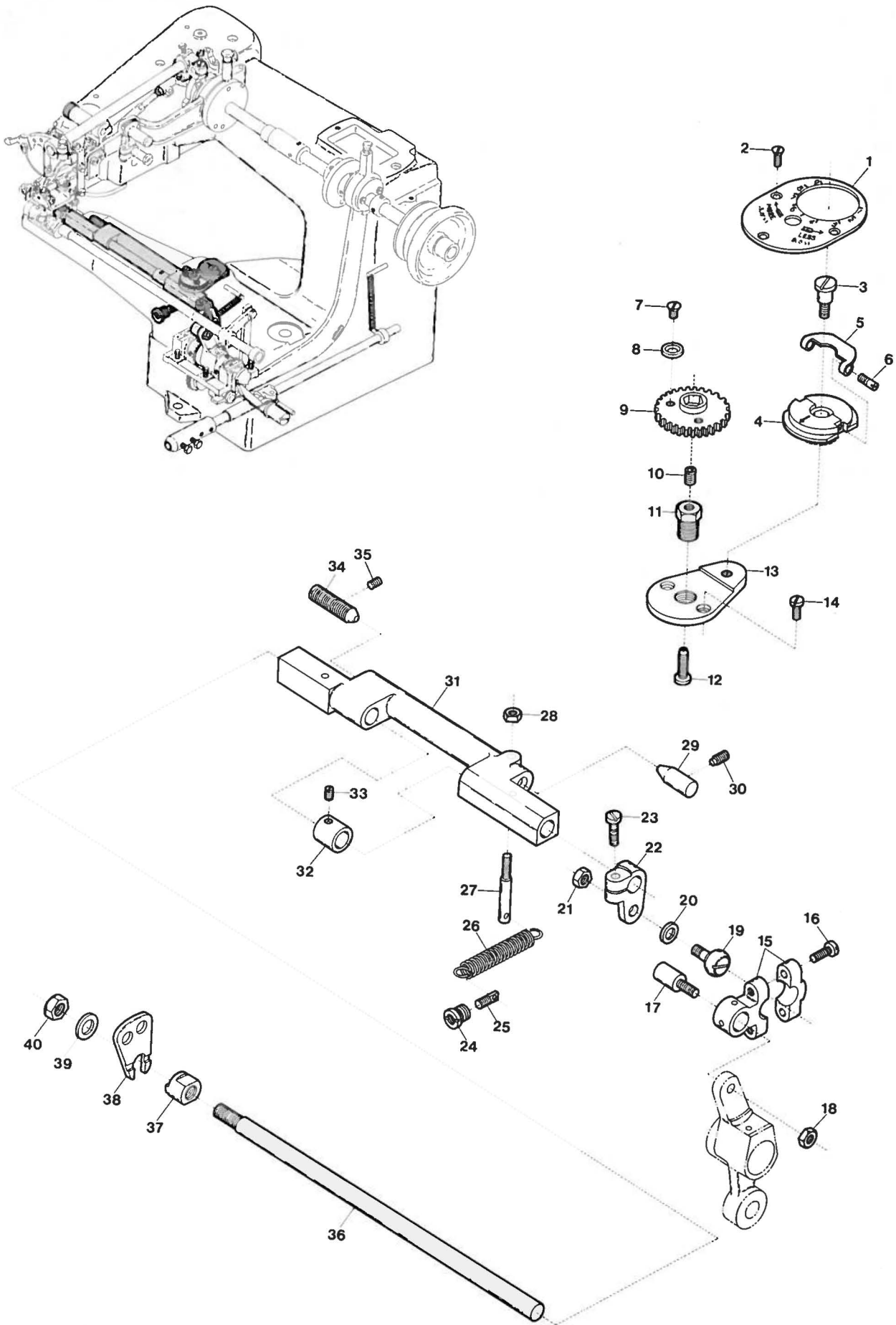

Ref. No.	Parts No.	Description	品名	Amt. Req.
1	80691	Ridge Form Regulator Graduations Plate	突上げ調節目盛板	1
2	5328	Screw for 80691	突上げ調節目盛板止ネジ	3
3	6520	Screw for 80693	突上げ調節器止ネジ	1
4	80693	Ridge Forming Regulator	突上げ調節器	1
5	80673	Ridge Forming Regulator Handle	突上げ調節ツマミ	1
6	6222	Screw for 80673	突上げ調節ツマミ止ネジ	2
7	5431	Screw for 675	ストップワッシャ止ネジ	2
8	675	Stopper Washer for 80693	ストップワッシャ	2
9	80694	Ridge Forming Regulator Gear (Large)	調節歯車(大)	1
10	3553	Locking Screw for 6855	ロックネジ	1
11	6900	Guide Screw for 6855	ガイドネジ	1
12	6855	Adjusting Screw for 80612	突上げ軸台調節ネジ	1
13	80692	Ridge Forming Regulator Flange	調節器フランジ	1
14	7616	Screw for 80692	調節器フランジ止ネジ	2
15	80618	Ridge Forming Plate Connecting Link	突上げリンク	1
16	4390	Screw for 80618	突上げリンク止ネジ	2
17	6242	Connecting Pin (with screwed head) for 80618	突上げリンク連結ピン	1
18	347	Nut for 6242	ナット	1
19	80609	Ball Stud	ネジ球	1
20	553	Washer for 80609	ワッシャ	1
21	355	Nut for 80609	ナット	1
22	80610	Ridge Forming Plate Shaft Lever	突上げ軸腕	1
23	5047	Screw for 80610	突上げ軸腕止ネジ	1
24	255	Adjusting Nut for 80614	バネ掛ケ調節ナット	1
25	6651	Screw for 80614	バネ掛ケ調節ネジ	1
26	80614	Ridge Forming Plate Cradle Spring	突上げ軸台バネ	1
27	6639	Screw for 80614	バネ掛ケネジ	1
28	338	Nut for 6639	ナット	1
29	80613	Pivot Bearing for 80612	ベンセンタ	1
30	3561	Screw for 80613	ベンセンタ止ネジ	1
31	80612	Ridge Forming Plate Cradle	突上げ軸台	1
32	80615	Ridge Forming Plate Shaft Collar	突上げ軸カラー	1
33	3393	Screw for 80615	突上げ軸カラー止ネジ	1
34	6892	Pivot Bearing Screw for 80612	突上げ軸台センタネジ	1
35	3559	Screw for 6892	突上げ軸台センタネジ止ネジ	1
36	80611	Ridge Forming Plate Shaft	突上げ軸	1
37	80616	Ridge Forming Plate Flange	突上げ板回り止メ	1
38	81609	Ridge Forming Plate	突上げ板	1
39	571	Washer for 81609	ワッシャ	1
40	371	Nut for 81609	ナット	1

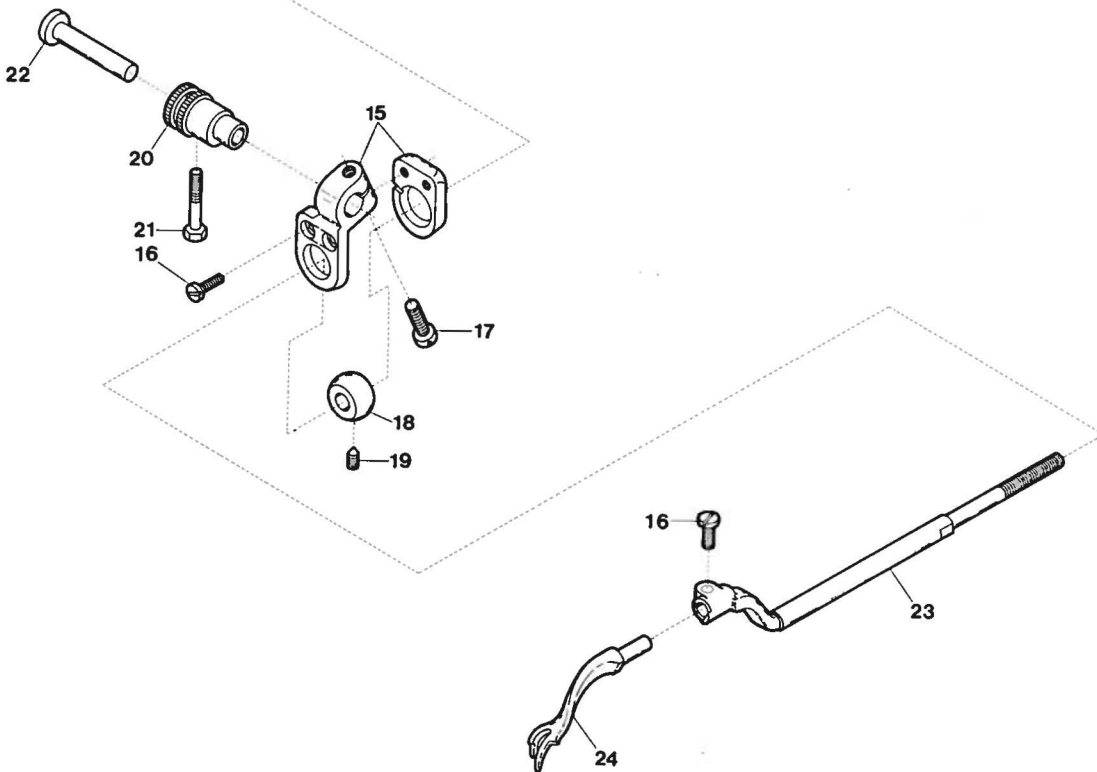
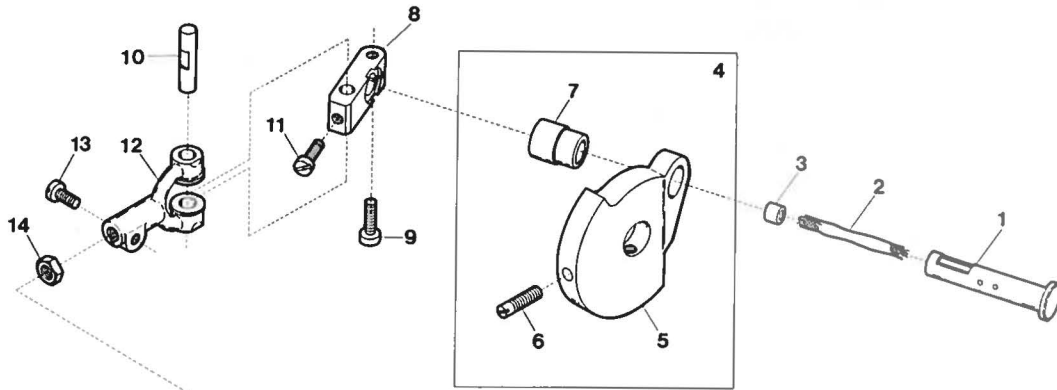
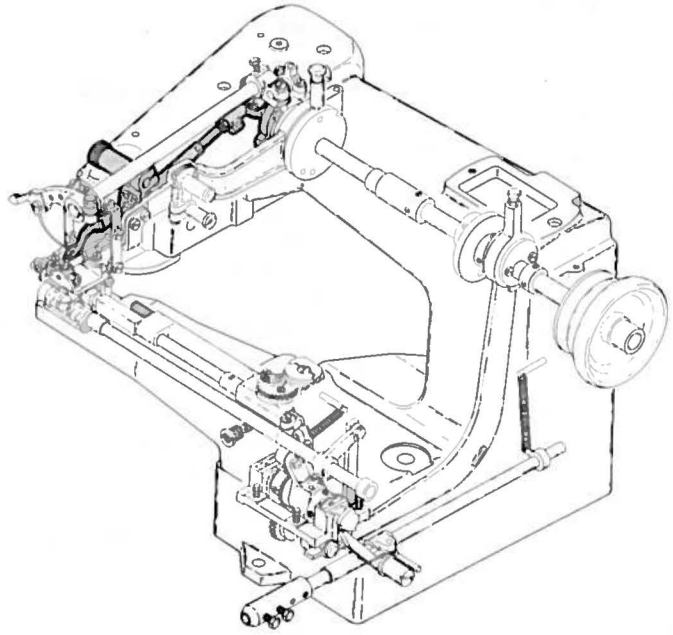

<u>Ref. No.</u>	<u>Parts No.</u>	<u>Description</u>	<u>品 名</u>	<u>Amt. Req.</u>
1	80403	Looper Driving Crank Pin	ルーパクランクピン	1
2	120	Oil Wick for 80403	油芯	1
3	80215	Oil Retainer (without hole)	油溜メ(穴無)	1
4	80400	Looper Driving Crank, Complete Set	ルーパクランク(組)	1
5	80401	Looper Driving Crank	ルーパクランク	1
6	3560	Screw for 80401	ルーパクランク止ネジ	2
7	80402	Looper Driving Crank Bushing	ルーパクランクブッシュ	1
8	80404	Looper Yoke Connecting Bracket	ルーパクランク抱キ	1
9	4280	Screw for 80404	ルーパクランク抱キ止ネジ	1
10	80405	Looper Yoke Pin	二又連結桿ピン	1
11	3472	Screw for 80405	二又連結桿ピン止ネジ	1
12	80406	Looper Yoke	二又連結桿	1
13	4399	Screw for 80406	二又連結桿止ネジ	1
14	354	Locking Nut for 80407	ロックナット	1
15	80415	Looper Carrier Ball Joint	球受ケ	1
16	4312	Screw for 80415, 80413	止ネジ	3
17	4554	Screw for 80412	ルーパ調節エキセンピン止ネジ	1
18	80408	Looper Carrier Ball	球	1
19	3392	Screw for 80408	球止ネジ	1
20	80411	Looper Ball Joint Adjusting Eccentric Sleeve	ルーパ調節エキセン	1
21	5558	Screw for 80411	ルーパ調節エキセン止ネジ	1
22	80412	Adjusting Eccentric Sleeve Pin	ルーパ調節エキセンピン	1
23	80407	Looper Carrier	ルーパ取付軸	1
24	80413	Looper	ルーパ	1

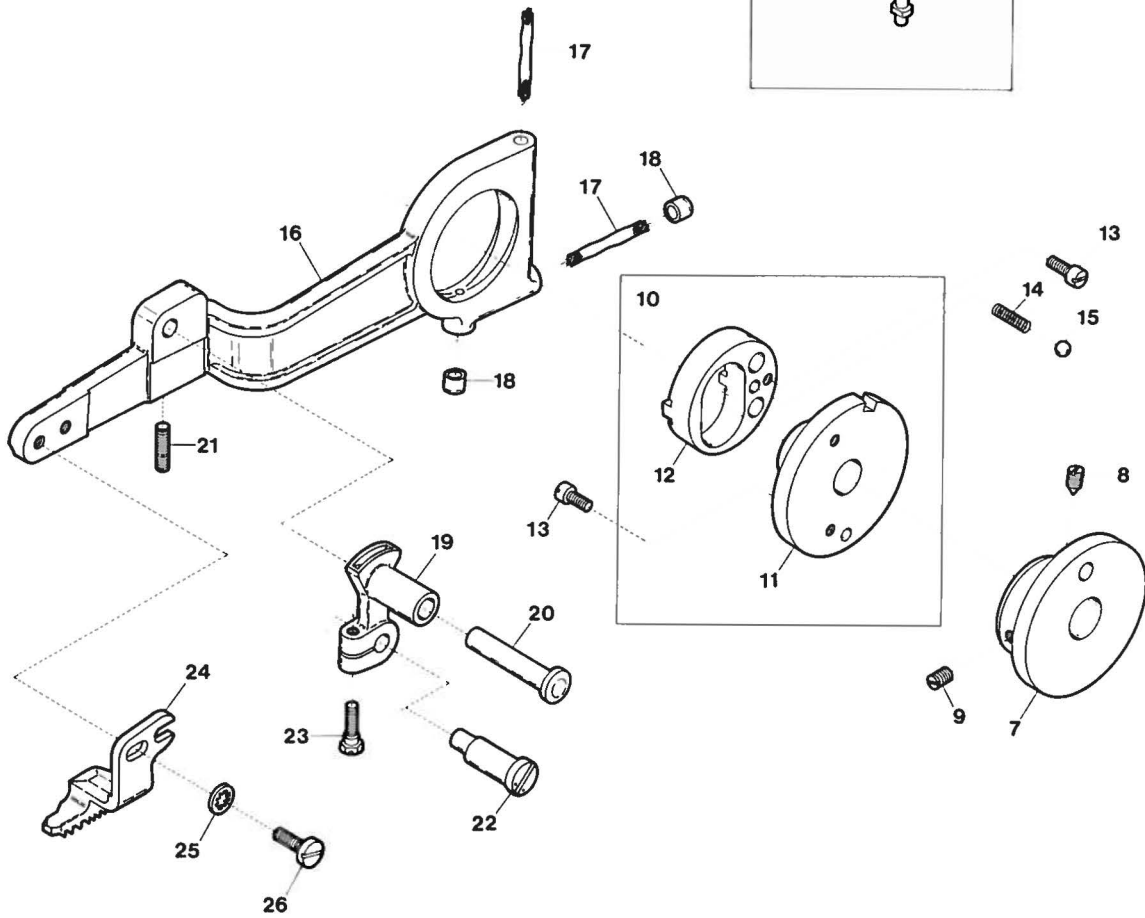
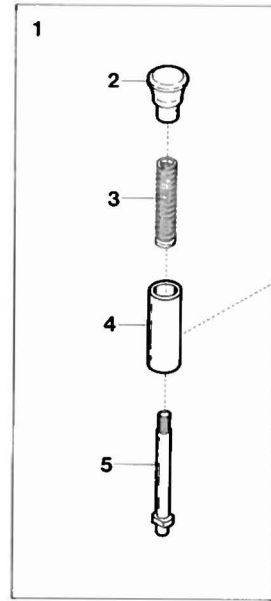
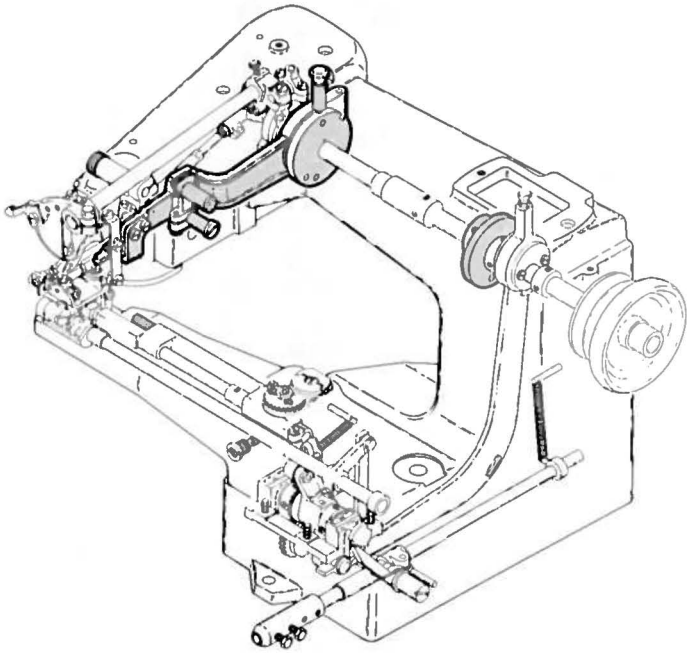

Ref. No.	Parts No.	Description	品名	Amt. Req.
1	80520	Feed Regulating Pushbutton, Complete Set	押シ釦(組)	1
2	80521	Feed Regulating Pushbutton	押シ釦	1
3	80523	Pushbutton Spring	押シ釦バネ	1
4	80524	Pushbutton Spring Sleeve	押シ釦スリーブ	1
5	80522	Pushbutton Shaft	押シ釦軸	1
6	3391	Screw for 80524	押シ釦スリーブ止ネジ	1
7	80531	Main Shaft Balance Weight	バランスウエイト	1
8	3557	Screw for 80531	バランスウエイト止ネジ	1
9	3555	Screw for 80531	バランスウエイト止ネジ	1
10	80500	Feed Regulator, Complete Set	送り調節器(組)	1
11	80501	Feed Regulator	送り調節器	1
12	80502	Feed Regulating Eccentric	送り調節エキセン	1
13	4242	Stopper Screw for 80502	送り調節エキセンストップネジ	3
14	80504	Feed Regulating Ball Spring	ボール押シバネ	1
15	80503	Feed Regulating Ball	調節器ボール	1
16	80505	Feed Lever	送り台	1
17	—	Oil Wick for 80505	油芯(毛糸)	2
18	80215	Oil Retainer (without hole)	油溜メ(穴無)	2
19	80506	Feed Link	送りリンク	1
20	80507	Feed Link Pin	送りリンクピン	1
21	3474	Screw for 80507	送りリンクピン止ネジ	1
22	80508	Feed Link Eccentric Pin	送りリンクエキセンピン	1
23	5547	Screw for 80508	送りリンクエキセンピン止ネジ	1
24	80510	Feed Dog	送り	1
25	552	Washer for 80510	ワッシャ	2
26	4471	Screw for 80510	送り止ネジ	2

CM-252

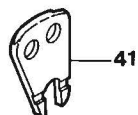
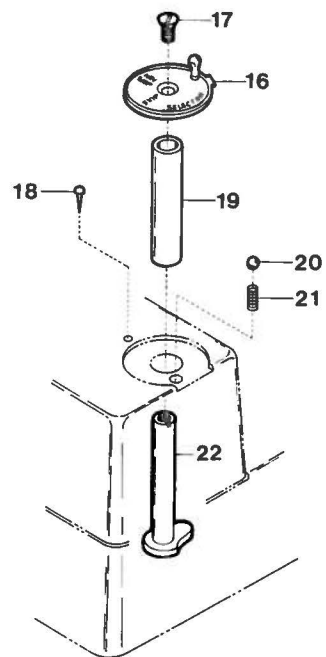
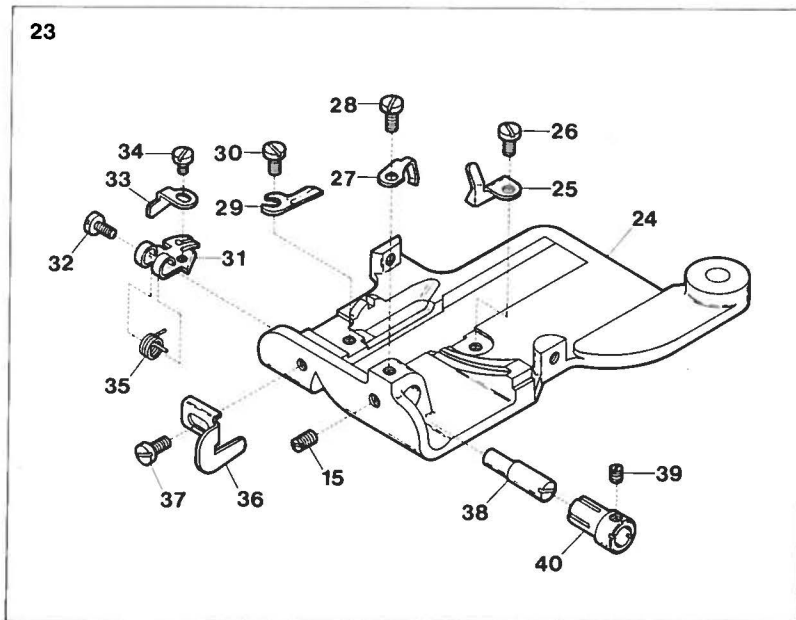
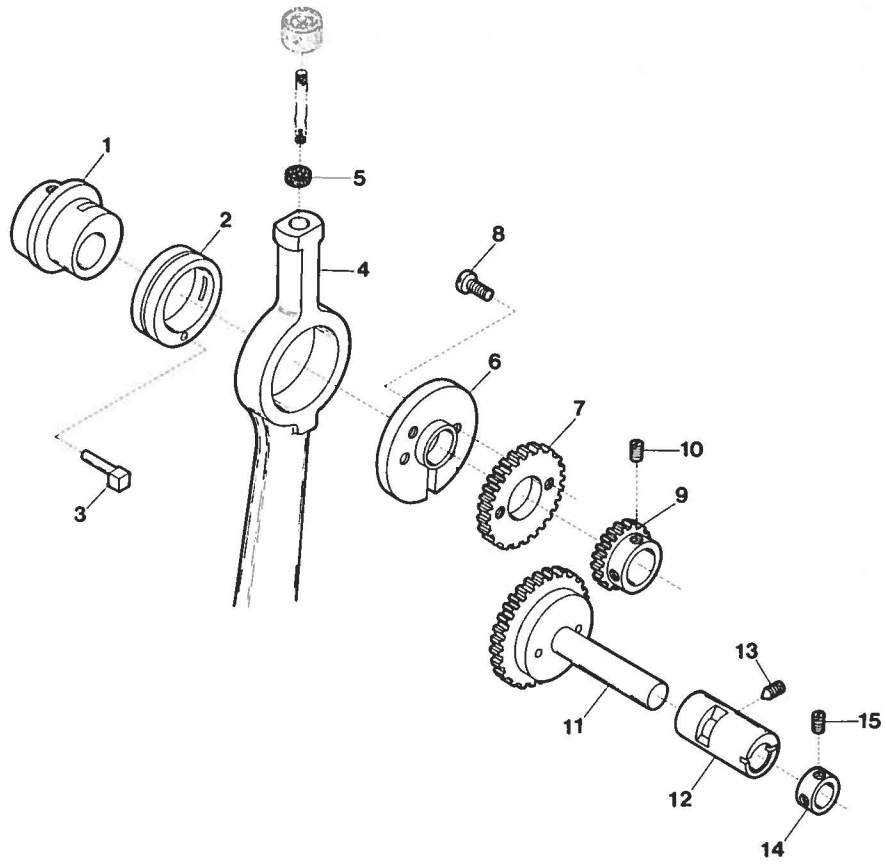

Ref. No.	Parts No.	Description	品名	Amt. Req.
1	80601	Ridge Forming Plate Eccentric	突上ゲエキセン	1
2	80602	Skipstitch Eccentric	スキップ縫エキセン	1
3	80624	Skipstitch Eccentric Pin	スキップ縫エキセンピン	1
4	80603	Ridge Forming Plate Connecting Rod	突上ゲロッド	1
5	80681	Oil Wick for 80603	油芯	1
6	80623	Main Shaft Gear Support	上軸歯車取付板	1
7	80646	Main Shaft Gear (Large)	上軸歯車(大)	1
8	4281	Screw for 80646	上軸歯車(大)止ネジ	2
9	80645	Main Shaft Gear (Small)	上軸歯車(小)	1
10	8047	Screw for 80645	上軸歯車(小)止ネジ	2
11	80647	Reduction Gear	減速歯車	1
12	80636	Reduction Gear Eccentric Bushing	エキセンブッシュ	1
13	3641	Screw for 80636	エキセンブッシュ止ネジ	1
14	80635	Reduction Gear Shaft Collar	減速歯車軸カラー	1
15	3393	Screw for 80635, 80356	止ネジ	3
16	80640	Skipstitch Selector	スキップ調節板	1
17	4475	Screw for 80640	止ネジ	1
18	721	Leading Rivet for 80640	スキップ止メ銀	1
19	80644	Skipstitch Cam Bushing	スキップ調節カムブッシュ	1
20	80503	Skipstitch Selector Ball	スキップ調節ボール	1
21	80675	Skipstitch Selector Ball Spring	ボール押シバネ	1
22	80643	Skipstitch Cam	スキップ調節カム	1
23	81345	Presser Foot Plate, Complete Set	押工受ケ(組)	1
24	80291	Presser Foot Plate	押工受ケ	1
25	80418	Chaining Finger	押工受ケツノ	1
26	4246	Screw for 80418	押工受ケツノ止ネジ	1
27	80357	Cloth Retainer Stopper	爪当り	1
28	4395	Screw for 80357	爪当り止ネジ	1
29	80358	Needle Guard	針受ケ	1
30	4393	Screw for 80358	針受ケ止ネジ	1
31	80352	Cloth Retainer	爪	1
32	4245	Screw for 80352	爪止ネジ	1
33	80353	Supplemental Cloth Retainer	補助爪	1
34	4241	Screw for 80353	補助爪止ネジ	1
35	80355	Cloth Retainer Spring	爪バネ	1
36	80360	Cloth Guide	爪下案内	1
37	4283	Screw for 80360	爪下案内止ネジ	1
38	80354	Cloth Retainer Adjusting Pin	爪エキセンピン	1
39	3312	Screw for 80354	爪エキセンピン止ネジ	1
40	80356	Cloth Retainer Spring Adjusting Sleeve	爪バネ調節スリーブ	1
41	80617	Ridge Forming Plate	突上ゲ板	1

CM-255

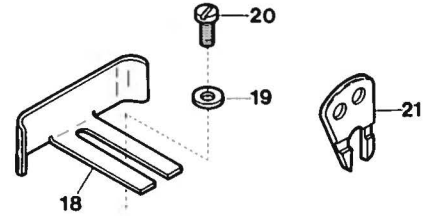
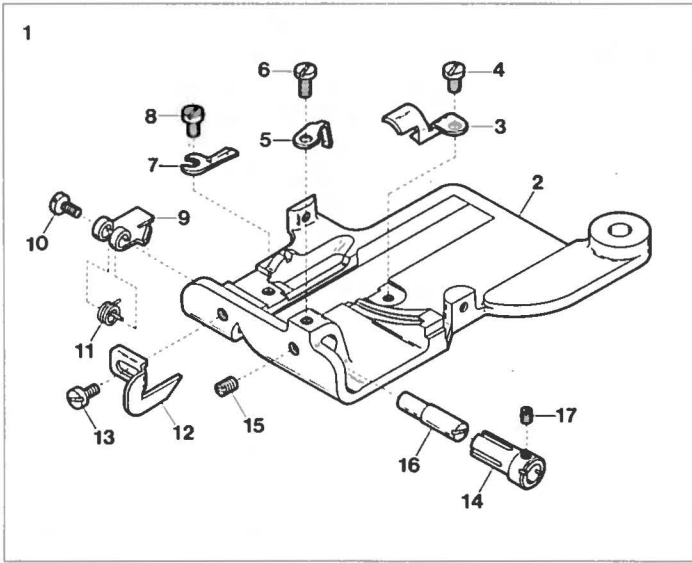

CM-256

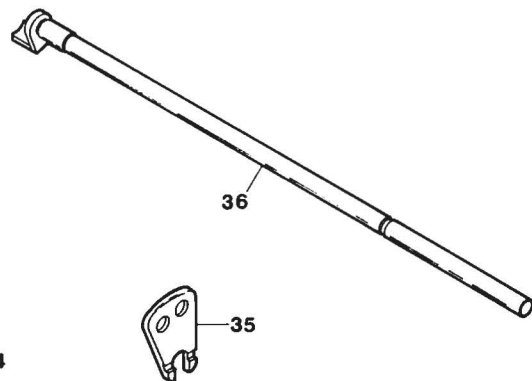
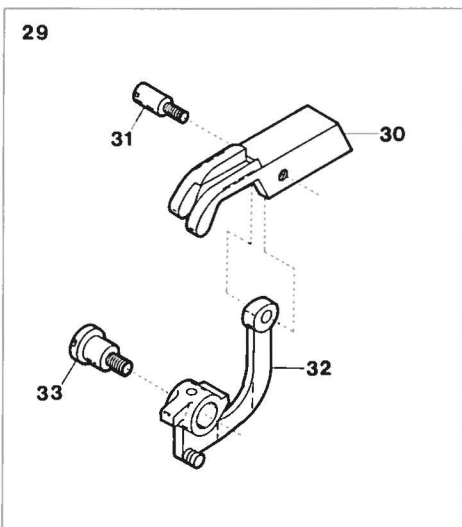
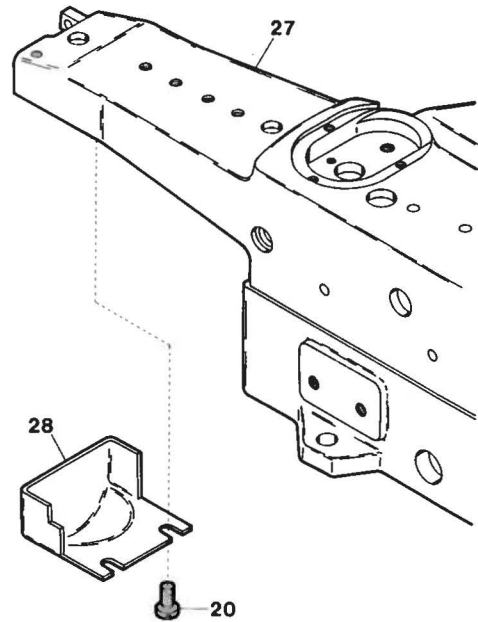
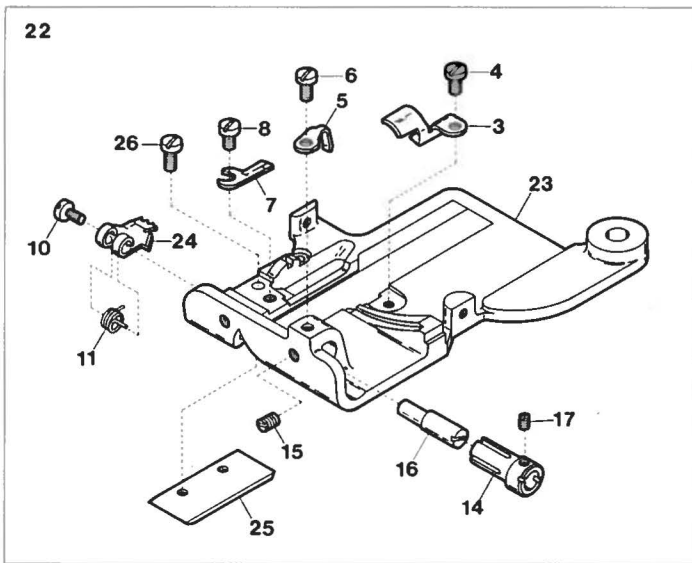

Ref. No.	Parts No.	Description	品名	Ami. Req.
1	81364	Presser Foot Plate, Complete Set	押工受ケ(組)	1
2	80291	Presser Foot Plate	押工受ケ	1
3	80418	Chaining Finger	押工受ケ角	1
4	4246	Screw for 80418	押工受ケ角止ネジ	1
5	80357	Cloth Retainer Stopper	爪当り	1
6	4395	Screw for 80357	爪当り止ネジ	1
7	80358	Needle Guard	針受ケ	1
8	4393	Screw for 80358	針受ケ止ネジ	1
9	81366	Cloth Retainer	爪	1
10	4245	Screw for 81366, 81352	爪止ネジ	1
11	80355	Cloth Retainer Spring	爪バネ	1
12	81354	Cloth Guide	爪下案内	1
13	4283	Screw for 81354	爪下案内止ネジ	1
14	80356	Cloth Retainer Spring Adjusting Sleeve	爪バネ調節スリーブ	1
15	3393	Screw for 80356	爪バネ調節スリーブ止ネジ	1
16	80354	Cloth Retainer Adjusting Pin	爪エキセンピン	1
17	3312	Screw for 80354	爪エキセンピン止ネジ	1
18	81901	Cloth Edge Guide	定規	1
19	540	Washer for 81901	ワッシャ	2
20	4474	Screw for 81901, 81102	止ネジ	2
21	81629	Ridge Forming Plate	突上げ板	1
22	81347	Presser Foot Plate, Complete Set	押工受ケ(組)	1
23	81348	Presser Foot Plate	押工受ケ	1
24	81352	Cloth Retainer	爪	1
25	81353	Presser Foot Supplementary Plate	押工受ケ補助板	1
26	4283	Screw for 81353	布滑り案内板止ネジ	2
27	81105	Machine Frame	アームベッド	1
28	81102	Cylinder Cover	腕前カバー	1
29	81299	Presser Foot, Complete Set	押工(組)	1
30	81303	Presser Foot	押工	1
31	6239	Screw for 81303	押工止ネジ	1
32	81300	Presser Foot Lever	押エレバー	1
33	6051	Screw for 81300	押エレバー止ネジ	1
34	81304	Presser Foot Spring	押エバネ	1
35	81603	Ridge Forming Plate	突上げ板	1
36	81301	Presser Foot Depress Shaft	押工軸	1

CM-257,258

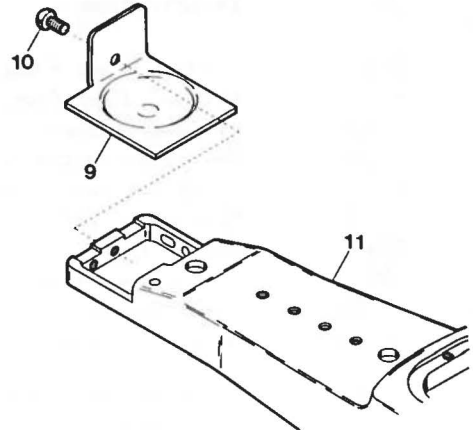
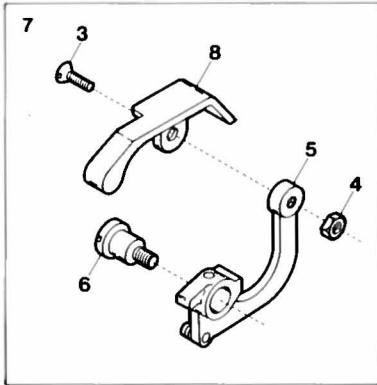
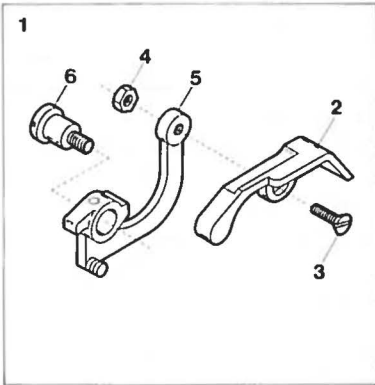

CM-257

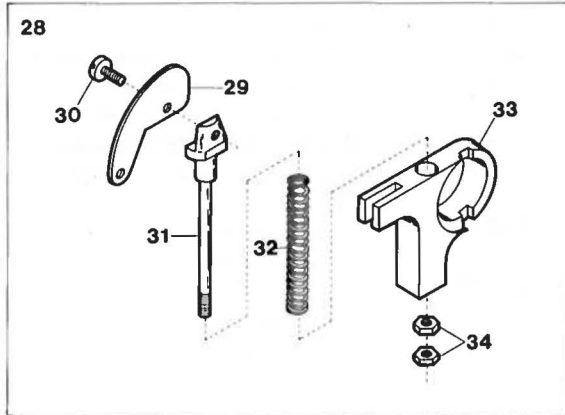
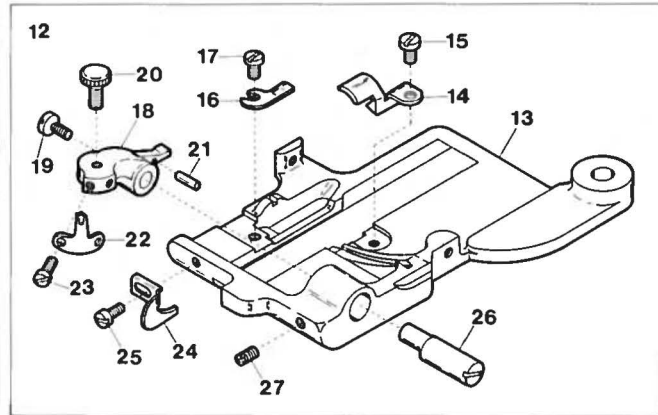

EXTRA PARTS

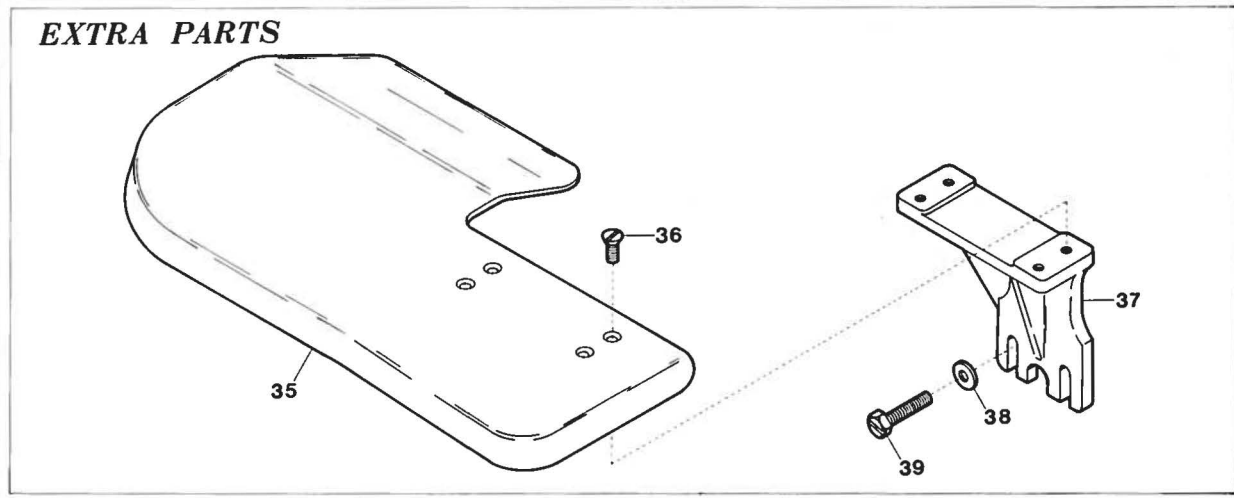

CM-258

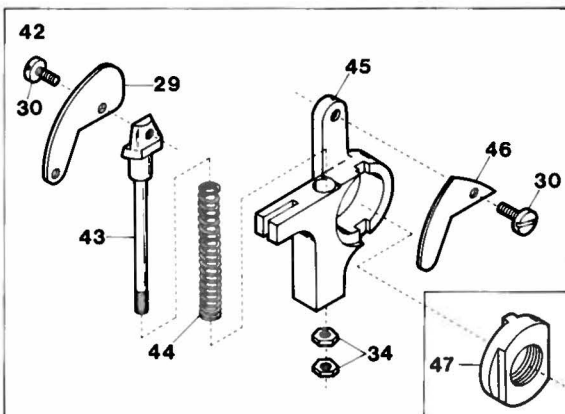
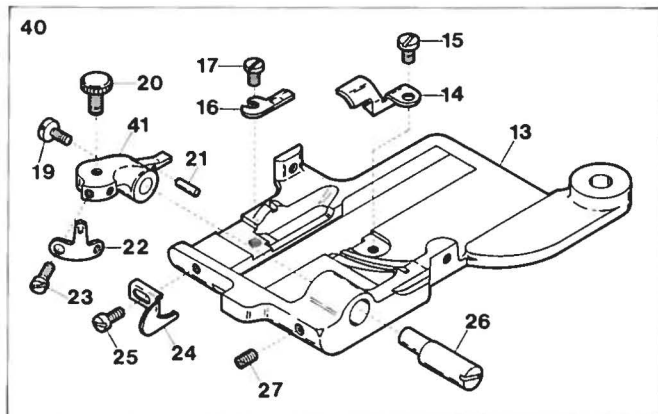

Ref. No.	Parts No.	Description	品名	Amt. Req.
1	81298	Presser Foot (Left), Complete Set	押エ(左)(組)	1
2	81307	Presser Foot (Left)	押エ(左)	1
3	6339	Screw for 81307, 81308	押エ止ネジ	2
4	339	Nut for 81307, 81308	ナット	2
5	81305	Presser Foot Lever	押エレバー	2
6	6033	Screw for 81305	押エレバー止ネジ	2
7	81297	Presser Foot (Right), Complete Set	押エ(右)(組)	1
8	81308	Presser Foot (Right)	押エ(右)	1
9	81116	Cylinder Cover	腕前カバー	1
10	4475	Screw for 81116	腕前カバー止ネジ	1
11	81130	Machine Frame	アームベッド	1
12	81397	Presser Foot Plate, Complete Set	押エ受ケ(組)	1
13	81398	Presser Foot Plate	押エ受ケ	1
14	80418	Chaining Finger	押エ受ケ角	1
15	4246	Screw for 80418	押エ受ケ角止ネジ	1
16	80358	Needle Guard	針受ケ	1
17	4393	Screw for 80358	針受ケ止ネジ	1
18	81372	Cloth Retainer	爪	1
19	4321	Screw for 81372, 81674	爪止ネジ	1
20	6435	Adjusting Screw for 81372, 81674	爪調節ネジ	1
21	80224	Cloth Retainer Stopper	爪当り	1
22	81810	Cloth Retainer Adjusting Spring Plate	爪調節バネ	1
23	4243	Screw for 81810	爪調節バネ止ネジ	2
24	81375	Cloth Guide	爪下案内	1
25	4283	Screw for 81375	爪下案内止ネジ	1
26	81374	Cloth Retainer Adjusting Pin	爪エキセンピン	1
27	3395	Screw for 81374	爪エキセンピン止ネジ	1
28	81640	Ridge Forming Plate, Complete Set	突上ゲ板(組)	1
29	81644	Ridge Forming Plate	突上ゲ板	1
30	4284	Screw for 81644, 81672	突上ゲ板止ネジ	1
31	81642	Ridge Forming Plate Holding Shaft	突上ゲ板取付軸	1
32	81643	Holding Shaft Spring	突上ゲ板取付軸バネ	1
33	81641	Holding Shaft Bracket	突上ゲ板取付軸台	1
34	329	Nut for 81642, 81671	ナット	2
35	81118	Cloth Plate (Extra)	クロスプレート(特注品)	1
36	5460	Screw for 81118	クロスプレート止ネジ	4
37	81117	Cloth Plate Support (Extra)	クロスプレート台(特注品)	1
38	580	Washer for 81117	ワッシャー	2
39	5560	Screw for 81117	クロスプレート台止ネジ	2
40	81680	Presser Foot Plate, Complete Set	押エ受ケ(組)	1
41	81674	Cloth Retainer	爪	1
42	81676	Ridge Forming Plate, Complete Set	突上ゲ板(組)	1
43	81671	Ridge Forming Plate Holding Shaft	突上ゲ板取付軸	1
44	81675	Holding Shaft Spring	突上ゲ板取付軸バネ	1
45	81673	Holding Shaft Bracket	突上ゲ板取付軸台	1
46	81672	Ridge Forming Plate (Small)	突上ゲ板(小)	1
47	81670	Ridge Forming Plate Flange	突上ゲ板回り止メ	1

CM-259

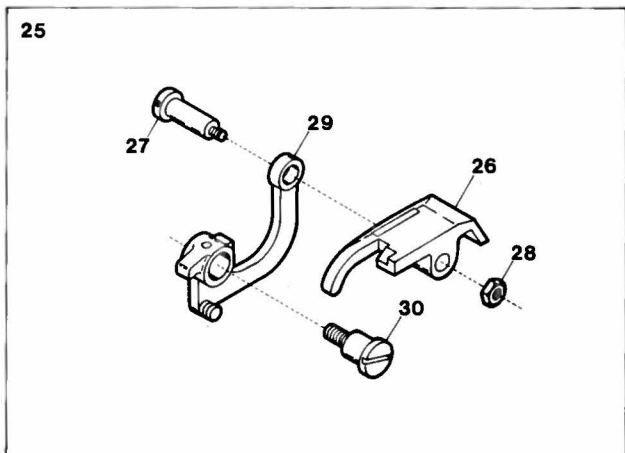
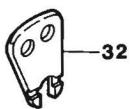
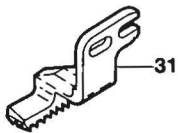
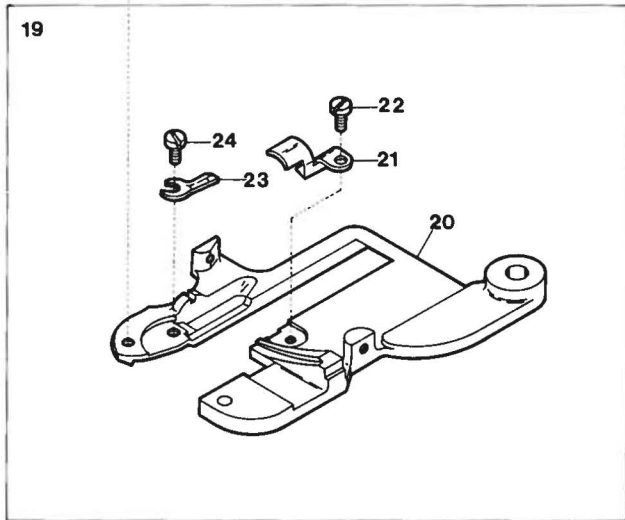
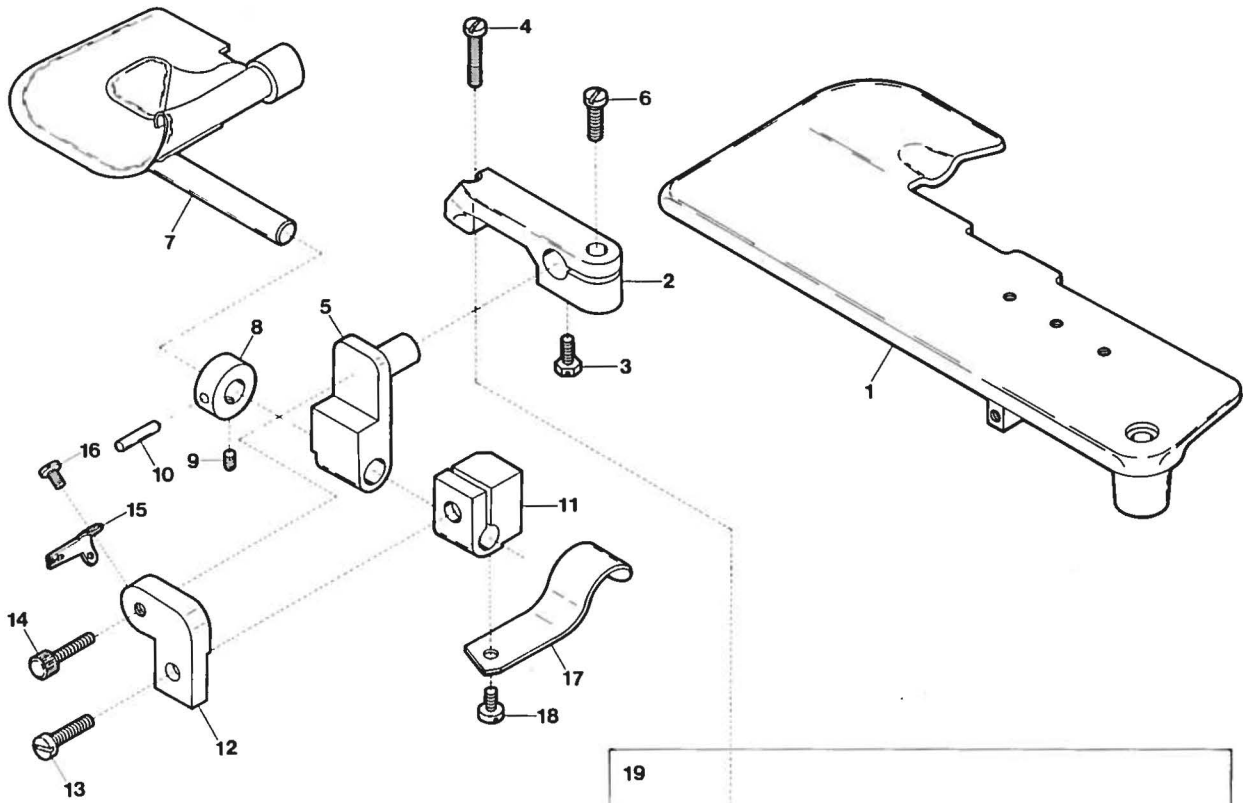

Ref. No.	Parts No.	Description	品 名	Amt. Req.
1	81121	Cloth Plate	クロスプレート	1
2	81801	Folder Bracket	定規支工腕	1
3	5531	Screw for 81801	定規支工腕止ネジ	1
4	4300	Screw for 81801	定規支工腕止ネジ	1
5	81802	Folder Stay	定規支工	1
6	4475	Screw for 81802	定規支工止ネジ	1
7	81925	Folder	定規	1
8	81808	Collar for Folder	定規カラー	1
9	3563	Screw for 81808	定規カラー止ネジ	1
10	711	Pin for 81808	定規カラーピン	1
11	81806	Folder Spring Support	定規バネ支工	1
12	81809	Folder Adjusting Screw Bracket	定規調節片	1
13	4476	Screw for 81809	定規調節片止ネジ	1
14	6433	Adjusting Screw for 81925	定規調節ネジ	1
15	81810	Adjusting Screw Retaining Spring	定規調節片バネ	1
16	4243	Screw for 81810	定規調節片バネ止ネジ	1
17	81807	Folder Spring	定規バネ	1
18	1227	Screw for 81807	定規バネ止ネジ	1
19	81380	Presser Foot Plate, Complete Set	押工受ケ(組)	1
20	81381	Presser Foot Plate	押工受ケ	1
21	80418	Chaining Finger	押工受ケ角	1
22	4246	Screw for 80418	押工受ケ角止ネジ	1
23	80358	Needle Guard	針受ケ	1
24	4393	Screw for 80358	針受ケ止ネジ	1
25	81315	Presser Foot, Complete Set	押工(組)	1
26	81317	Presser Foot	押工	1
27	6056	Screw for 81317	押工止ネジ	1
28	339	Nut for 81317	ナット	1
29	81316	Presser Foot Lever	押エレバー	1
30	6051	Screw for 81316	押エレバー止ネジ	1
31	81506	Feed Dog	送り	1
32	81645	Ridge Forming Plate	突上ゲ板	1

CM-260

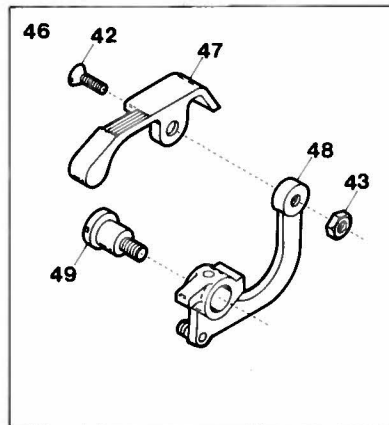
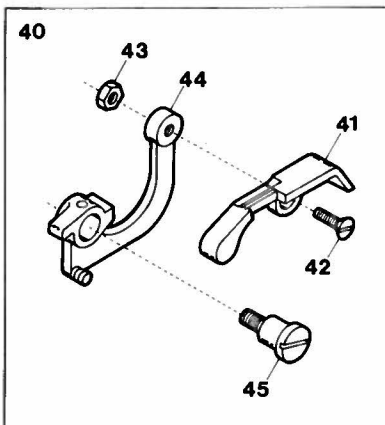
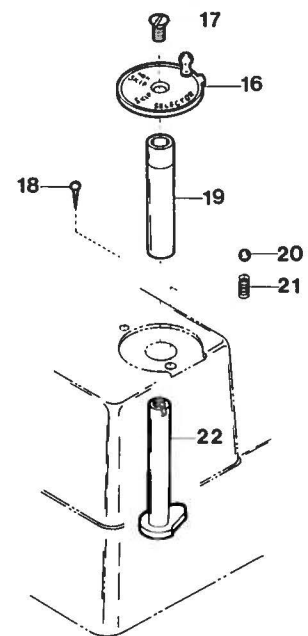
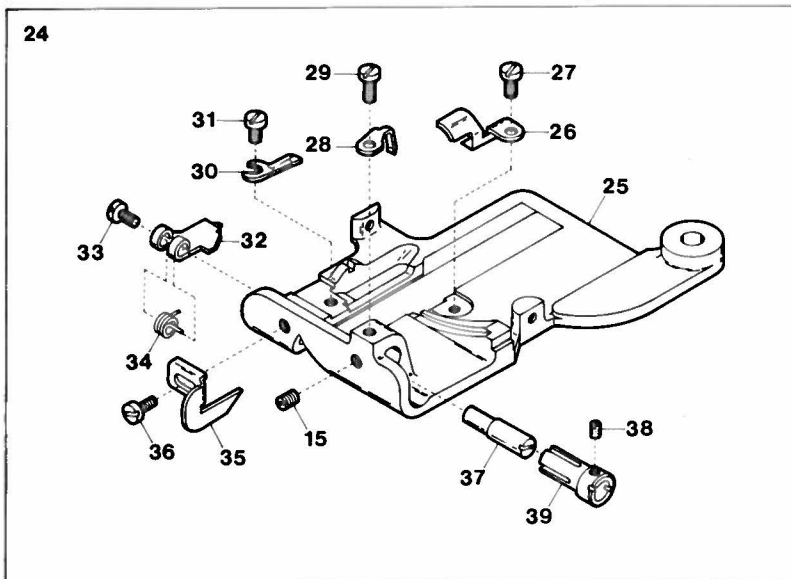
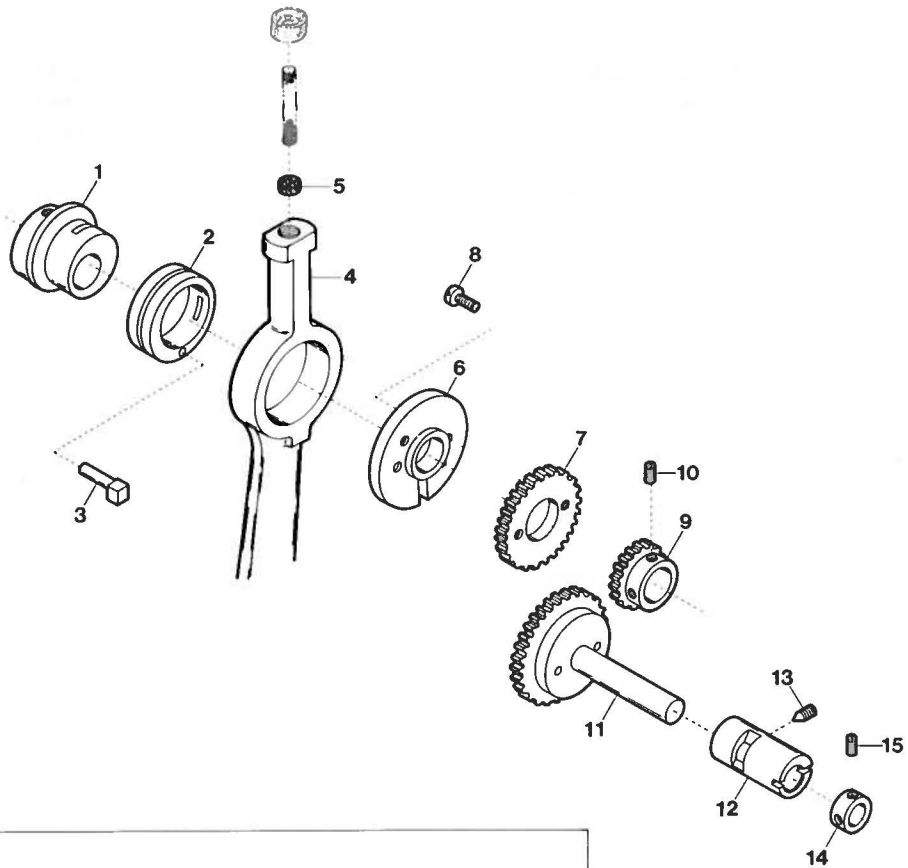

Ref. No.	Parts No.	Description	品名	Amt. Req.
1	80601	Ridge Forming Plate Eccentric	突上ゲエキセン	1
2	80602	Skipstitch Eccentric	スキップ縫エキセン	1
3	80624	Skipstitch Eccentric Pin	スキップ縫エキセンピン	1
4	80603	Ridge Forming Plate Connecting Rod	突上ゲロッド	1
5	80681	Oil Wick for 80603	油芯	1
6	80623	Main Shaft Gear Support	上軸歯車取付板	1
7	80646	Main Shaft Gear (Large)	上軸歯車(大)	1
8	4281	Screw for 80646	上軸歯車(大)止ネジ	2
9	80645	Main Shaft Gear (Small)	上軸歯車(小)	1
10	8047	Screw for 80645	上軸歯車(小)止ネジ	2
11	80647	Reduction Gear	減速歯車	1
12	80636	Reduction Gear Eccentric Bushing	エキセンブッシュ	1
13	3641	Screw for 80636	エキセンブッシュ止ネジ	1
14	80635	Reduction Gear Shaft Collar	減速歯車軸カラー	1
15	3393	Screw for 80635, 80356	止ネジ	3
16	80640	Skipstitch Selector	スキップ調節板	1
17	4475	Screw for 80640	止ネジ	1
18	721	Leading Rivet for 80640	スキップ止メ鉄	1
19	80644	Skipstitch Cam Bushing	スキップ調節カムブッシュ	1
20	80503	Skipstitch Selector Ball	スキップ調節ボール	1
21	80675	Skipstitch Selector Ball Spring	ボール押シバネ	1
22	80643	Skipstitch Cam	スキップ調節カム	1
23	81982	Ridge Forming Plate	突上ゲ板	1
24	81979	Presser Foot Plate, Complete Set	押工受ケ(組)	1
25	80291	Presser Foot Plate	押工受ケ	1
26	80418	Chaining Finger	押工受ケ角	1
27	4246	Screw for 80418	押工受ケ角止ネジ	1
28	80357	Cloth Retainer Stopper	爪当り	1
29	4395	Screw for 80357	爪当り止ネジ	1
30	80358	Needle Guard	針受ケ	1
31	4393	Screw for 80358	針受ケ止ネジ	1
32	81981	Cloth Retainer	爪	1
33	4245	Screw for 81981	爪止ネジ	1
34	80355	Cloth Retainer Spring	爪バネ	1
35	81354	Cloth Guide	爪下案内	1
36	4283	Screw for 81354	爪下案内止ネジ	1
37	80354	Cloth Retainer Adjusting Pin	爪エキセンピン	1
38	3312	Screw for 80354	爪エキセンピン止ネジ	1
39	80356	Cloth Retainer Spring Adjusting Sleeve	爪バネ調節スリーブ	1
40	81970	Presser Foot (Left), Complete Set	押工(左)(組)	1
41	81967	Presser Foot (Left)	押工(左)	1
42	6339	Screw for 81967, 81966	押工止ネジ	2
43	339	Nut for 81967, 81966	ナット	2
44	81969	Presser Foot Lever (Left)	押エレバー(左)	1
45	6033	Screw for 81969	押エレバー(左)止ネジ	1
46	81971	Presser Foot (Right), Complete Set	押工(右)(組)	1
47	81966	Presser Foot (Right)	押工(右)	1
48	80346	Presser Foot Lever (Right)	押エレバー(右)	1
49	6051	Screw for 80346	押エレバー(右)止ネジ	1

CM-261

1

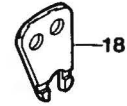
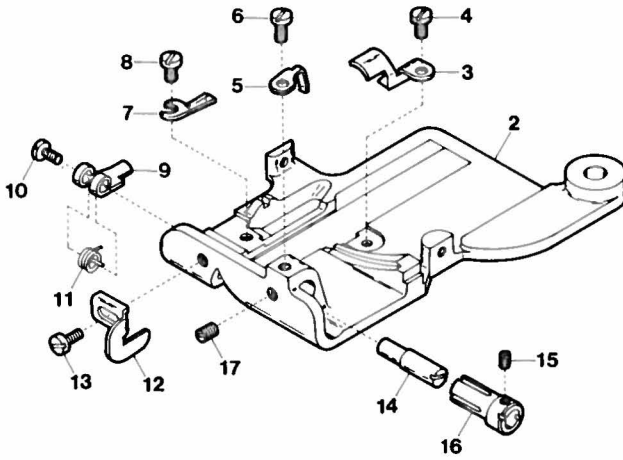

CM-265

19

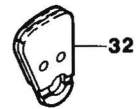
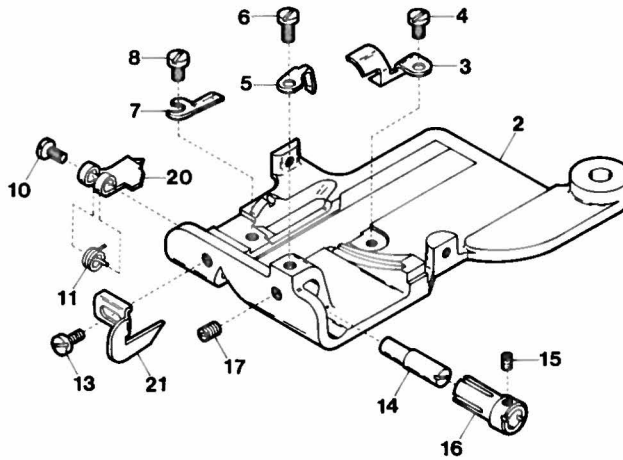

22

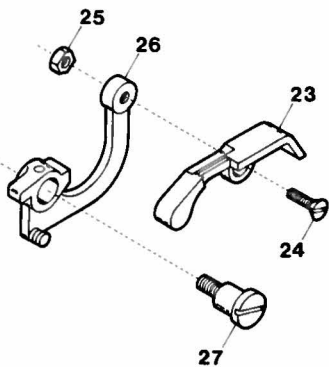

28

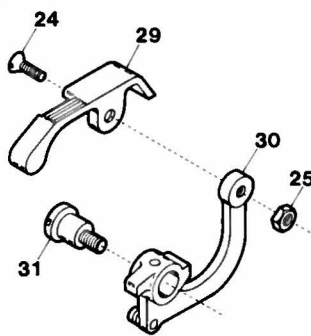

Ref. No.	Parts No.	Description	品 名	Amt. Req.
1	80680	Presser Foot Plate, Complete Set	押工受ケ(組)	1
2	80291	Presser Foot Plate	押工受ケ	1
3	80418	Chaining Finger	押工受ケ角	1
4	4246	Screw for 80418	押工受ケ角止ネジ	1
5	80357	Cloth Retainer Stopper	爪当リ	1
6	4395	Screw for 80357	爪当リ止ネジ	1
7	80358	Needle Guard	針受ケ	1
8	4393	Screw for 80358	針受ケ止ネジ	1
9	81424	Cloth Retainer	爪	1
10	4245	Screw for 81424, 81981	爪止ネジ	1
11	80355	Cloth Retainer Spring	爪バネ	1
12	80360	Cloth Guide	爪下案内	1
13	4283	Screw for 80360, 81354	爪下案内止ネジ	1
14	80354	Cloth Retainer Adjusting Pin	爪エキセンピン	1
15	3312	Screw for 80354	爪エキセンピン止ネジ	1
16	80356	Cloth Retainer Spring Adjusting Sleeve	爪バネ調節スリーブ	1
17	3393	Screw for 80356	爪バネ調節スリーブ止ネジ	1
18	80678	Ridge Forming Plate	突上げ板	1
19	81979	Presser Foot Plate, Complete Set	押工受ケ(組)	1
20	81981	Cloth Retainer	爪	1
21	81354	Cloth Guide	爪下案内	1
22	81970	Presser Foot (Left), Complete Set	押工(左)(組)	1
23	81967	Presser Foot (Left)	押工(左)	1
24	6339	Screw for 81967, 81966	押工止ネジ	2
25	339	Nut for 81967, 81966	ナット	2
26	81969	Presser Foot Lever (Left)	押エレバー(左)	1
27	6033	Screw for 81969	押エレバー(左)止ネジ	1
28	81971	Presser Foot (Right), Complete Set	押工(右)(組)	1
29	81966	Presser Foot (Right)	押工(右)	1
30	80346	Presser Foot Lever (Right)	押エレバー(右)	1
31	6051	Screw for 80346	押エレバー(右)止ネジ	1
32	81982	Ridge Forming Plate	突上げ板	1

CM-262

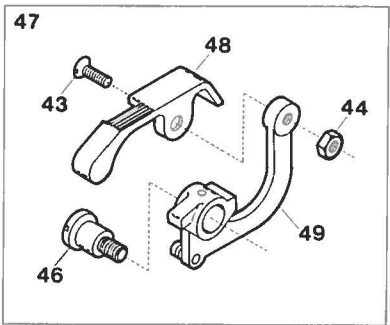
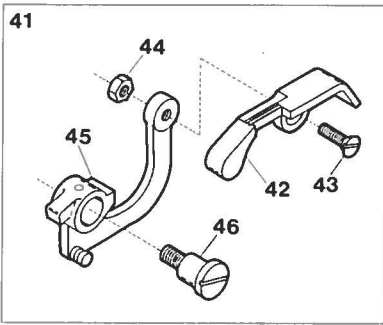
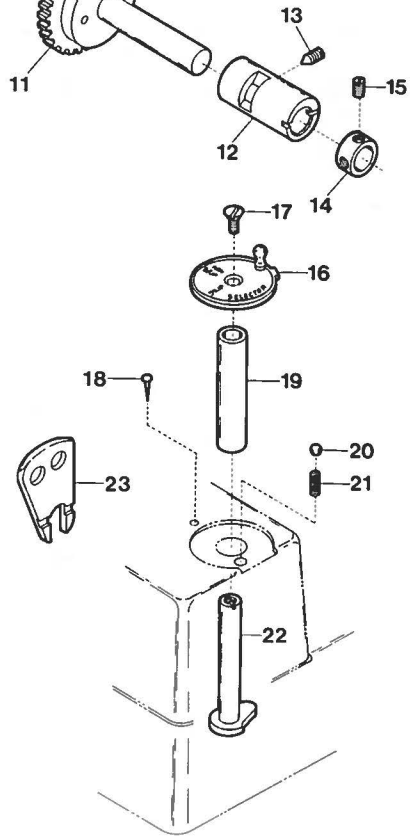
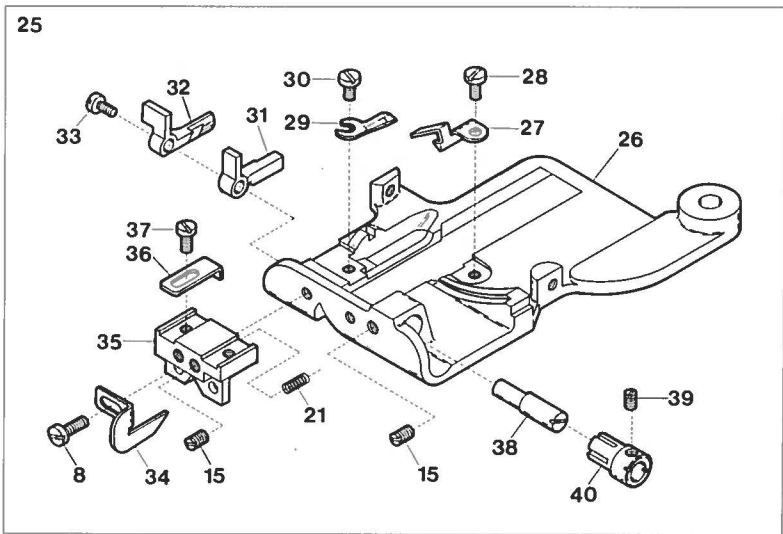
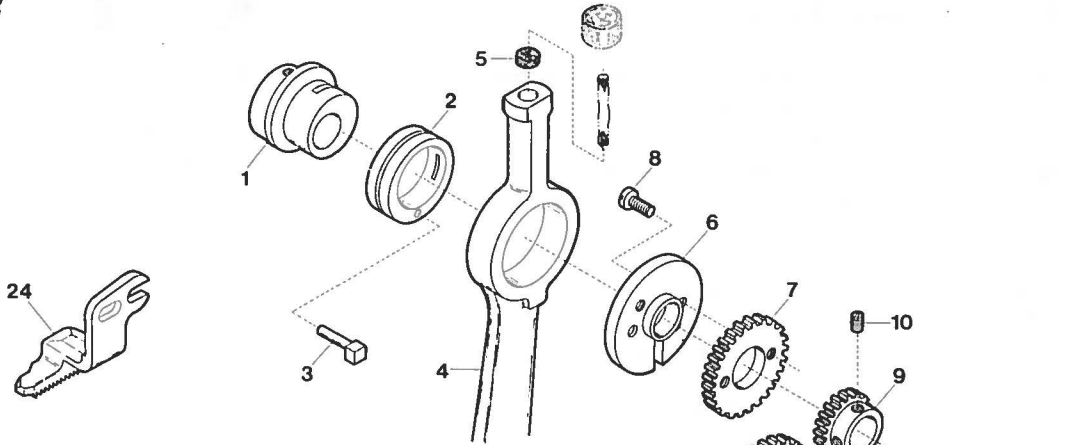

Ref. No.	Parts No.	Description	品名	Amt. Req.
1	80601	Ridge Forming Plate Eccentric	突上ゲエキセン	1
2	80602	Skipstitch Eccentric	スキップ縫エキセン	1
3	80624	Skipstitch Eccentric Pin	スキップ縫エキセンピン	1
4	80603	Ridge Forming Plate Connecting Rod	突上ゲロッド	1
5	80681	Oil Wick for 80603	油芯	1
6	80623	Main Shaft Gear Support	上軸歯車取付板	1
7	80646	Main Shaft Gear (Large)	上軸歯車(大)	1
8	4281	Screw for 80646, 80385	止ネジ	4
9	80645	Main Shaft Gear (Small)	上軸歯車(小)	1
10	8047	Screw for 80645	上軸歯車(小)止ネジ	2
11	80647	Reduction Gear	減速歯車	1
12	80636	Reduction Gear Eccentric Bushing	エキセンブッシュ	1
13	3641	Screw for 80636	エキセンブッシュ止ネジ	1
14	80635	Reduction Gear Shaft Collar	減速歯車軸カラー	1
15	3393	Screw for 80635, 80675, 80356	止ネジ	5
16	80640	Skipstitch Selector	スキップ調節板	1
17	4475	Screw for 80640	スキップ調節板止ネジ	1
18	721	Leading Rivet for 80640	スキップ止メ鉄	1
19	80644	Skipstitch Cam Bushing	スキップ調節カムブッシュ	1
20	80503	Skipstitch Selector Ball	スキップ調節ボール	1
21	80675	Spring for 80503, 80387, 80388	ボール・爪押シバネ	3
22	80643	Skipstitch Cam	スキップ調節カム	1
23	80627	Ridge Forming Plate	突上ゲ板	1
24	80373	Feed Dog	送り	1
25	80389	Presser Foot Plate, Complete Set	押工受け(組)	1
26	80383	Presser Foot Plate	押工受け	1
27	80382	Chaining Finger	押工受けツノ	1
28	4246	Screw for 80382	押工受けツノ止ネジ	1
29	80358	Needle Guard	針受け	1
30	4393	Screw for 80358	針受け止ネジ	1
31	80387	Cloth Retainer (Right)	爪(右)	1
32	80388	Cloth Retainer (Left)	爪(左)	1
33	4245	Screw for 80387, 80388	爪止ネジ	1
34	80397	Cloth Guide	爪下案内	1
35	80385	Cloth Retainer Adjusting Plate Support	爪調節板取付台	1
36	80386	Cloth Retainer Adjusting Plate	爪調節板	2
37	1228	Screw for 80386	爪調節板止ネジ	2
38	80354	Cloth Retainer Adjusting Pin	爪エキセンピン	1
39	3312	Screw for 80354	爪エキセンピン止ネジ	1
40	80356	Cloth Retainer Adjusting Sleeve	爪バネ調節スリーブ	1
41	80399	Presser Foot (Left), Complete Set	押工(左)(組)	1
42	80396	Presser Foot (Left)	押工(左)	1
43	6339	Screw for 80396, 80346	押工止ネジ	2
44	339	Nut for 80396, 80346	ナット	2
45	80321	Presser Foot Lever (Left)	押エレバー(左)	1
46	6051	Screw for 80321, 80346	押エレバー止ネジ	2
47	80398	Presser Foot (Right), Complete Set	押工(右)(組)	1
48	80395	Presser Foot (Right)	押工(右)	1
49	80346	Presser Foot Lever (Left)	押エレバー(右)	1

CM-263(1)

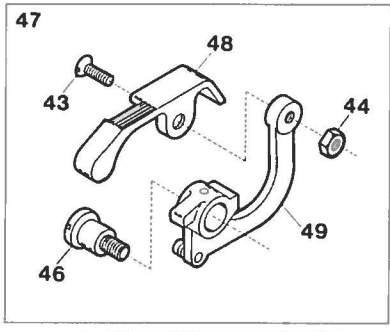
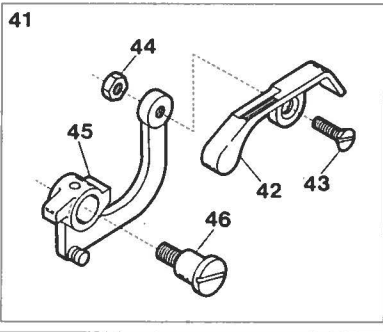
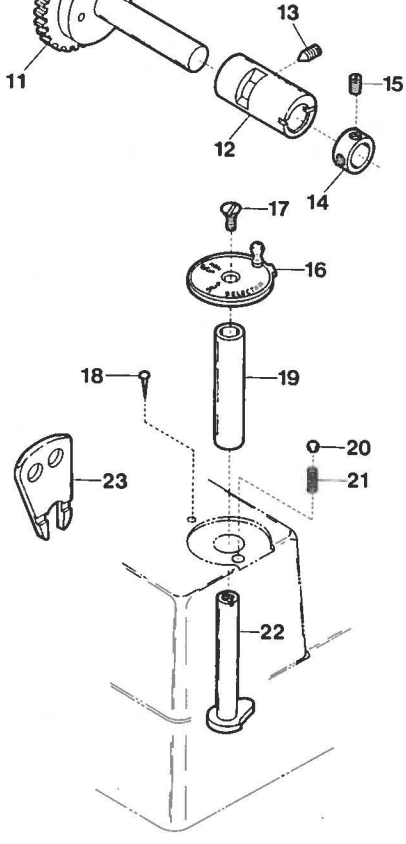
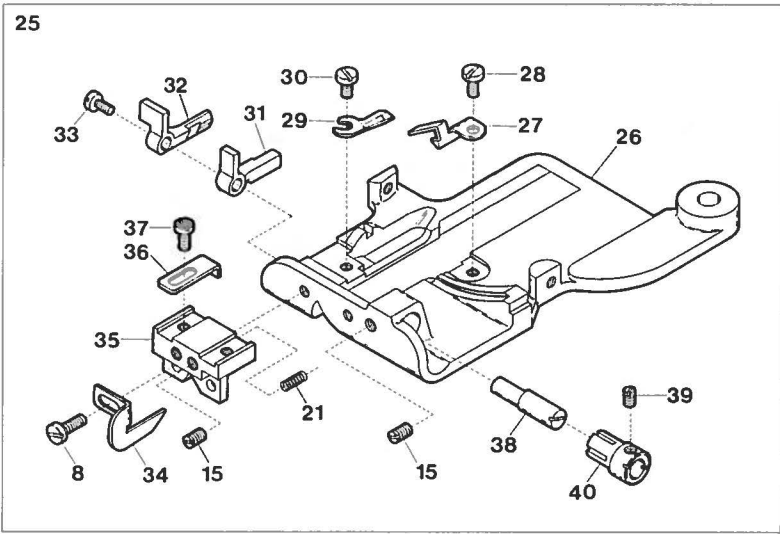
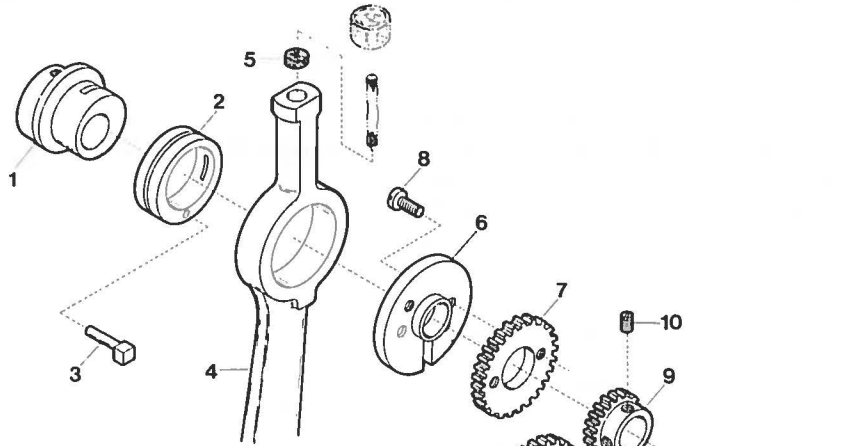

Ref. No.	Parts No.	Description	品名	Amt. Req.
1	80601	Ridge Forming Plate Eccentric	突上ゲエキセン	1
2	80602	Skipstitch Eccentric	スキップ縫エキセン	1
3	80624	Skipstitch Eccentric Pin	スキップ縫エキセンピン	1
4	80603	Ridge Forming Plate Connecting Rod	突上ゲロッド	1
5	80681	Oil Wick for 80603	油芯	1
6	80623	Main Shaft Gear Support	上軸歯車取付板	1
7	80646	Main Shaft Gear (Large)	上軸歯車(大)	1
8	4281	Screw for 80646, 80385	止ネジ	4
9	80645	Main Shaft Gear (Small)	上軸歯車(小)	1
10	8047	Screw for 80645	上軸歯車(小)止ネジ	2
11	80647	Reduction Gear	減速歯車	1
12	80636	Reduction Gear Eccentric Bushing	エキセンブッシュ	1
13	3641	Screw for 80636	エキセンブッシュ止ネジ	1
14	80635	Reduction Gear Shaft Collar	減速歯車軸カラー	1
15	3393	Screw for 80635, 80675, 80356	止ネジ	5
16	80640	Skipstitch Selector	スキップ調節板	1
17	4475	Screw for 80640	スキップ調節板止ネジ	1
18	721	Leading Rivet for 80640	スキップ止メ鋸	1
19	80644	Skipstitch Cam Bushing	スキップ調節カムブッシュ	1
20	80503	Skipstitch Selector Ball	スキップ調節ボール	1
21	80675	Spring for 80503, 80387, 80388	ボール・爪押シバネ	3
22	80643	Skipstitch Cam	スキップ調節カム	1
23	80627	Ridge Forming Plate	突上ゲ板	1
24				
25	80389	Presser Foot Plate, Complete Set	押工受ケ(組)	1
26	80383	Presser Foot Plate	押工受ケ	1
27	80382	Chaining Finger	押工受ケツノ	1
28	4246	Screw for 80382	押工受ケツノ止ネジ	1
29	80358	Needle Guard	針受ケ	1
30	4393	Screw for 80358	針受ケ止ネジ	1
31	80387	Cloth Retainer (Right)	爪(右)	1
32	80388	Cloth Retainer (Left)	爪(左)	1
33	4245	Screw for 80387, 80388	爪止ネジ	1
34	80397	Cloth Guide	爪下案内	1
35	80385	Cloth Retainer Adjusting Plate Support	爪調節板取付台	1
36	80386	Cloth Retainer Adjusting Plate	爪調節板	2
37	1228	Screw for 80386	爪調節板止ネジ	2
38	80354	Cloth Retainer Adjusting Pin	爪エキセンピン	1
39	3312	Screw for 80354	爪エキセンピン止ネジ	1
40	80356	Cloth Retainer Adjusting Sleeve	爪バネ調節スリーブ	1
41	80441	Presser Foot (Left), Complete Set	押工(左)(組)	1
42	80434	Presser Foot (Left)	押工(左)	1
43	6339	Screw for 80434, 80433	押工止ネジ	2
44	339	Nut for 80434, 80433	ナット	2
45	80347	Presser Foot Lever (Left)	押エレバー(左)	1
46	6051	Screw for 80347, 80320	押エレバー止ネジ	2
47	80440	Presser Foot (Right), Complete Set	押工(右)(組)	1
48	80433	Presser Foot (Right)	押工(右)	1
49	80320	Presser Foot Lever (Left)	押エレバー(右)	1

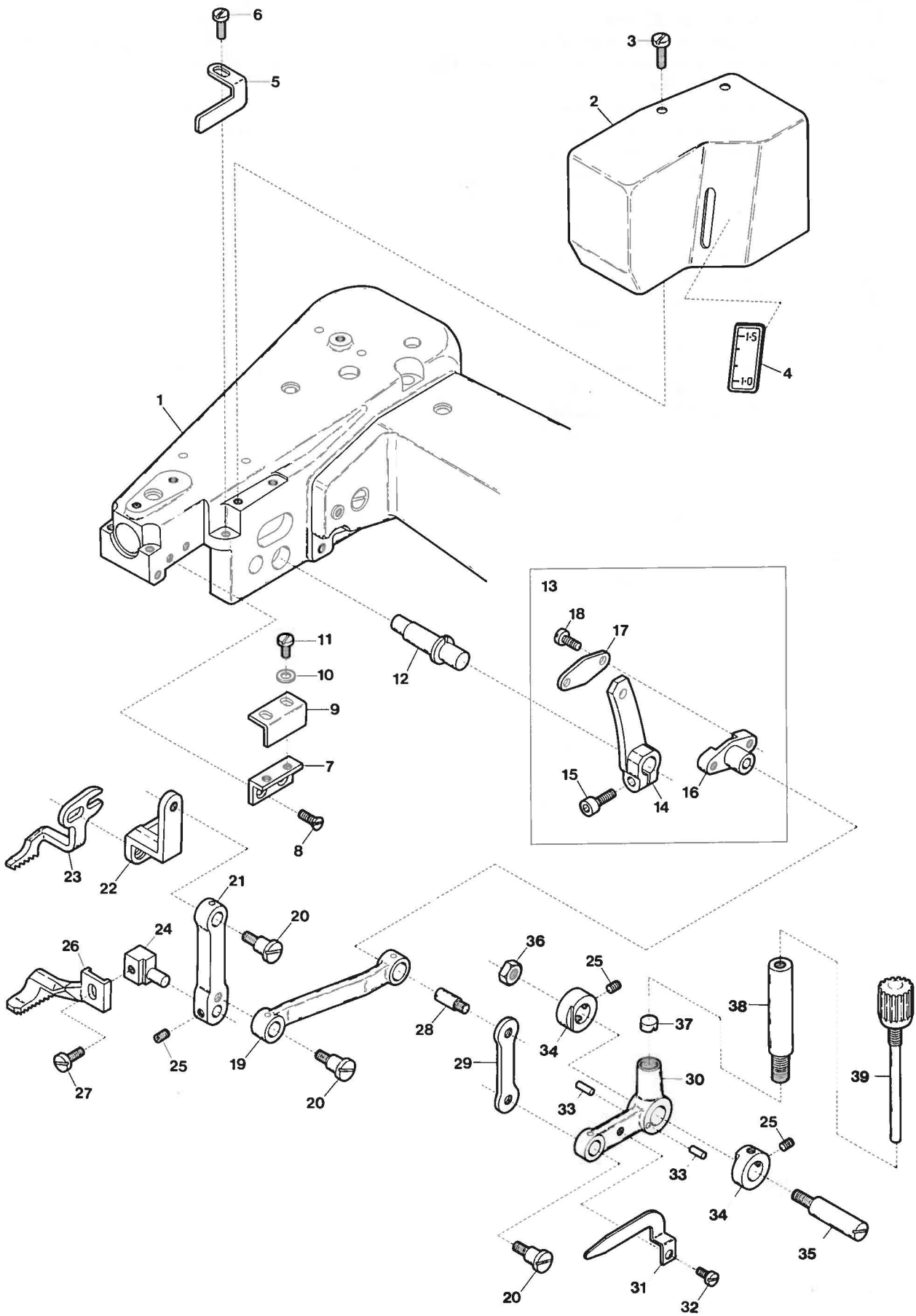

Ref. No.	Parts No.	Description	品名	Amt. Req.
1	80450	Machine Frame	ベッド(組)	1
2	80419	Mechanism Cover	装置カバー	1
3	4406	Screw for 80419	装置カバー止ネジ	2
4	80443	Differential Graduations	差動目盛	1
5	80432	Driving Connection Guide	ガイド(右)	1
6	4353	Screw for 80432	ガイド(右)止ネジ	1
7	81890	Driving Connection Bracket Guide Support	ガイド(左)取付台	1
8	7621	Screw for 81890	ガイド(左)取付台止ネジ	2
9	81889	Driving Connection Bracket Guide	ガイド(左)	1
10	535	Washer for 81889	ワッシャー	2
11	4358	Screw for 81889	ガイド(左)止ネジ	2
12	81752	Feed Link Eccentric Pin	送りリンクエキセンピン	1
13	80442	Differential Feed Regulator, Complete Set	差動送り調節器(組)	1
14	80425	Differential Feed Regulator	差動送り調節器	1
15	5028	Screw for 80425	差動送り調節器止ネジ	1
16	81877	Differential Feed Regulating Slider	差動送リスライダ	1
17	81758	Differential Feed Regulating Slider Cap	スライダ蓋	1
18	8145	Screw for 81758	スライダ蓋止ネジ	2
19	80426	Differential Feed Dog Driving Lever	差動送リレバー	1
20	5510	Screw for 80426, 80427, 80424	止ネジ	3
21	80427	Differential Feed Dog Driving Connection	差動送リリンク	1
22	80430	Driving Connection Bracket	差動送リリンク取付台	1
23	80431	Main Feed Dog	送り	1
24	80428	Differential Feed Dog Holder	差動送り取付台	1
25	3638	Screw for 80428, 80423	止ネジ	5
26	80429	Differential Feed Dog	差動送り	1
27	1175	Screw for 80429	差動送り止ネジ	1
28	5512	Screw for 80424	止ネジ	1
29	80424	Differential Feed Control Inner Lever	調節中レバー	1
30	80421	Differential Feed Control Lever	調節レバー	1
31	80444	Differential Graduations Pointer	差動目盛指示板	1
32	4317	Screw for 80444	差動目盛指示板止ネジ	1
33	722	Stopper Pin for 80421	ストッパピン	2
34	80423	Differential Feed Control Lever Stopper	調節レバーストッパ	1
35	80422	Differential Feed Control Lever Shaft	調節レバー取付軸	1
36	366	Nut for 80422	ナット	1
37	80435	Differential Feed Control Lever Fixing Piece	調節レバー固定ブロック	1
38	80439	Fixing Screw Sleeve	固定ネジスリーブ	1
39	80438	Fixing Screw	固定ネジ	1

CM-270 (1)

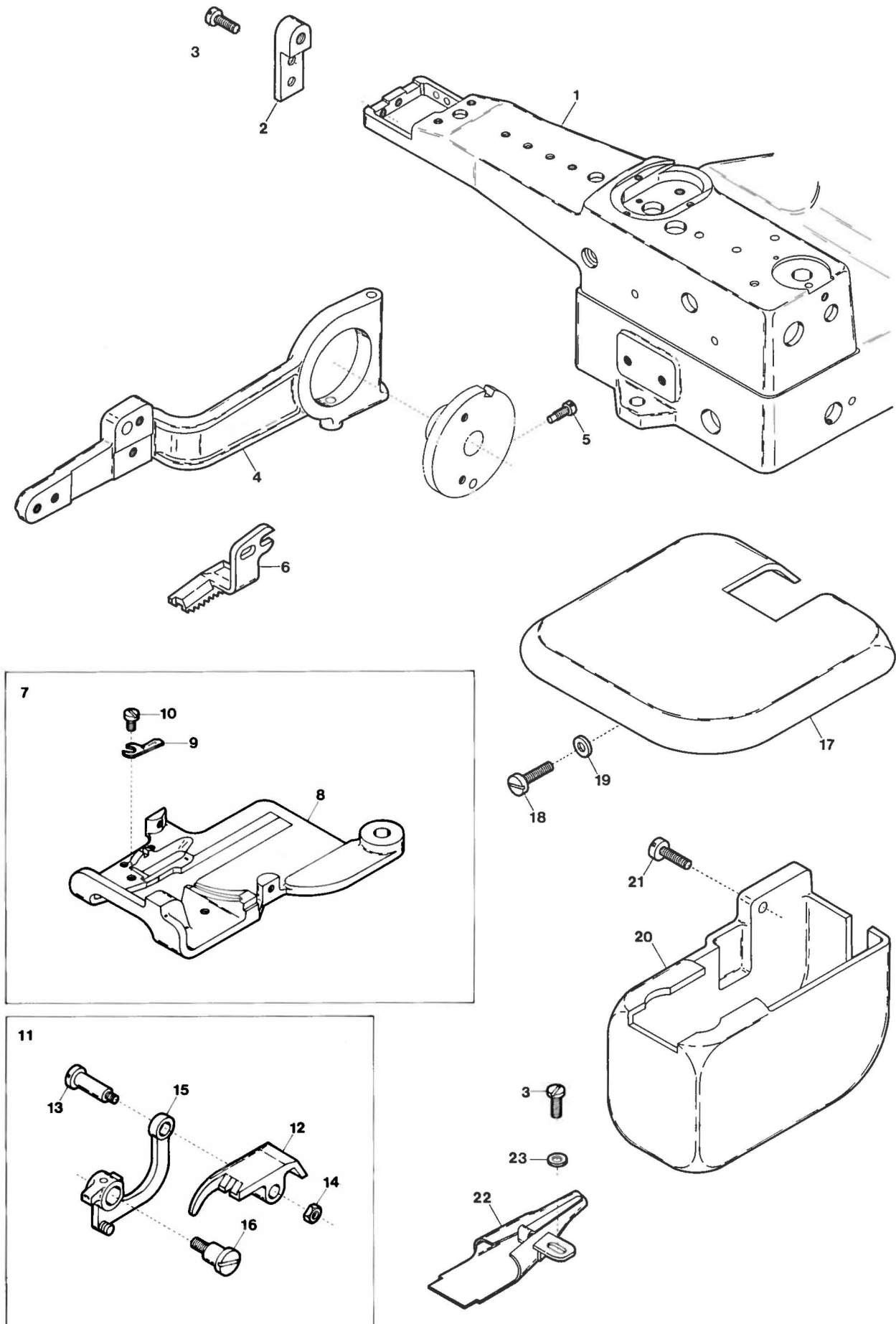

Ref. No.	Parts No.	Description	品名	Amt. Req.
1	81180	Machine Frame	アームベッド(組)	1
2	81312	Presser Foot Lever Holder	押エレバー支工	1
3	4481	Screw for 81312, 81976	止ネジ	2
4	81500	Feed Lever	送り台	1
5	5033	Stopper Screw for Feed Regulator	送り調節器ストップバネジ	1
6	81502	Feed Dog	送り	1
7	81410	Presser Foot Plate, Complete Set	押工受け(組)	1
8	81411	Presser Foot Plate	押工受け	1
9	81412	Needle Guard	針受け	1
10	4393	Screw for 81412	針受け止ネジ	1
11	81315	Presser Foot, Complete Set	押工(組)	1
12	81336	Presser Foot	押工	1
13	6056	Screw for 81336	押工止ネジ	1
14	339	Nut for 81336	ナット	1
15	81316	Presser Foot Lever	押エレバー	1
16	6051	Screw for 81316	押エレバー止ネジ	1
17	81112	Cloth Cutting Mechanism Basement Cover	メス装置台カバー	1
18	4472	Screw for 81112	メス装置台カバー止ネジ	1
19	554	Washer for 81112	ワッシャ	1
20	81111	Lower Knife Driving Connecting Rod Cover	下メスロッドカバー	1
21	4476	Screw for 81111	下メスロッドカバー止ネジ	1
22	81976	Folder	定規	1
23	554	Washer for 81976	ワッシャ	1

CM-270(2)

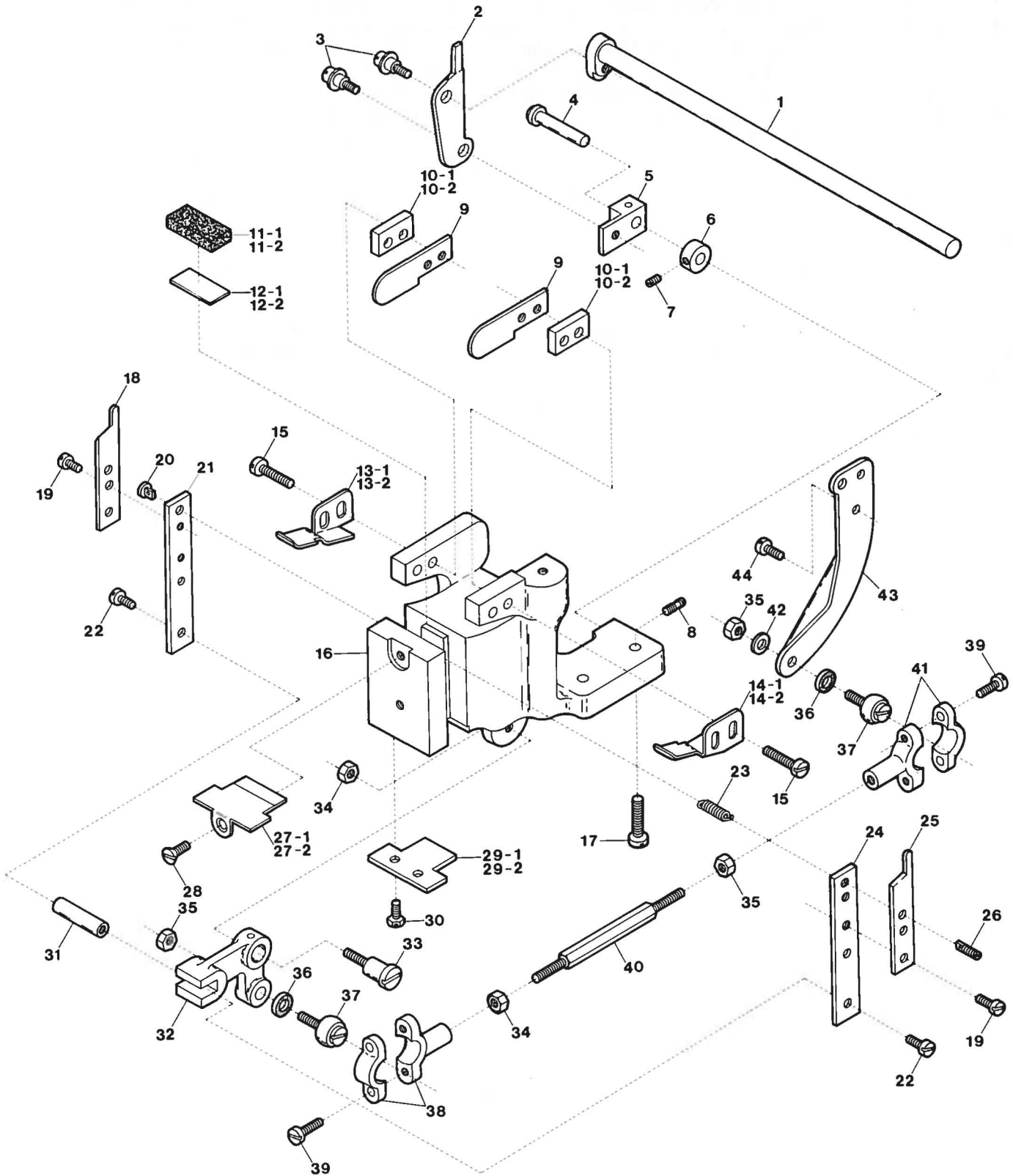

Ref. No.	Parts No.	Description	品名	Amt. Req.
1	81610	Ridge Forming Plate Shaft	突上ゲ軸	1
2	81613	Ridge Forming Plate	突上ゲ板	1
3	6032	Screw for 81613	突上ゲ板止ネジ	2
4	81615	Ridge Forming Plate Plunger Link Pin	突上ゲ板リンクピン	1
5	81614	Ridge Forming Plate Plunger Link	突上ゲ板リンク	1
6	81616	Collar for 81615	突上ゲ板リンクピンカラー	1
7	3393	Screw for 81616	突上ゲ板リンクピンカラー止ネジ	1
8	3472	Screw for 81615	突上ゲ板リンクピン止ネジ	1
9	81702	Upper Knife	上メス	2
10-1	81703	Upper Knife Spacing Plate (7.94mm)	上メス幅決メ板	2
10-2	81731	" " (9.52mm) (Extra)	" (特注品)	2
11-1	81726	Oil Pad (7.94mm)	オイルパッド	1
11-2	81735	" (9.52mm) (Extra)	" (特注品)	1
12-1	81727	Oil Pad Support (7.94mm)	オイルパッド支工板	1
12-2	81736	" " (9.52mm) (Extra)	" (特注品)	1
13-1	81704	Chip Guard (Left) (7.94mm)	切屑除ケ(左)	1
13-2	81732	" " (9.52mm) (Extra)	" " (特注品)	1
14-1	81705	Chip Guard (Right) (7.94mm)	切屑除ケ(右)	1
14-2	81733	" " (9.52mm) (Extra)	" " (特注品)	1
15	4389	Screw for Chip Guard	切屑除ケ止ネジ	4
16	81701	Cloth Cutting Mechanism Basement	メス装置台	1
17	4472	Screw for 81701	メス装置台止ネジ	2
18	81724	Lower Knife (Left)	下メス(左)	1
19	4394	Screw for 81724, 81725	下メス止ネジ	4
20	81722	Lower Knife Tension Spring Latch	下メスバネ掛ケ	1
21	81719	Lower Knife Holder (Left)	下メス取付板(左)	1
22	4321	Screw for 81719, 81720	下メス取付板止ネジ	2
23	81721	Lower Knife Tension Spring	下メスバネ	1
24	81720	Lower Knife Holder (Right)	下メス取付板(右)	1
25	81725	Lower Knife (Right)	下メス(右)	1
26	6637	Adjusting Screw for 81721	下メスバネ調節ネジ	1
27-1	81728	Oil Pad Presser (7.94mm)	オイルパッド押工板	1
27-2	81737	" " (9.52mm) (Extra)	" (特注品)	1
28	5431	Screw for 81728, 81737	オイルパッド押工板止ネジ	1
29-1	81723	Lower Knife Spacing Plate (7.94mm)	下メス幅決メ板	1
29-2	81734	" " (9.52mm) (Extra)	" (特注品)	1
30	5531	Screw for 81723, 81734	下メス幅決メ板止ネジ	2
31	81718	Lower Knife Holder Pin	下メス取付板ピン	1
32	81717	Lower Knife Driving Arm	下メス振り腕	1
33	6052	Screw for 81717	下メス振り腕止ネジ	1
34	356	Nut for 81717, 81714	ナット	2
35	355	Nut for 80609, 81714	ナット	3
36	579	Fiber Racking for 80609	バッキン	2
37	80609	Ball Stud	下メスロッド球	2
38	81710	Lower Knife Connecting Rod (Front)	下メスロッド(前)	1
39	4391	Screw for 81710, 81709	下メスロッド止ネジ	4
40	81714	Lower Knife Rods Connection	下メスロッド連結棉	1
41	81709	Lower Knife Connecting Rod (Rear)	下メスロッド(後)	1
42	553	Washer for 80609	ワッシャ	1
43	81711	Lower Knife Driving Link	下メスリンク	1
44	5552	Screw for 81711	下メスリンク止ネジ	2

"T"DEVICE

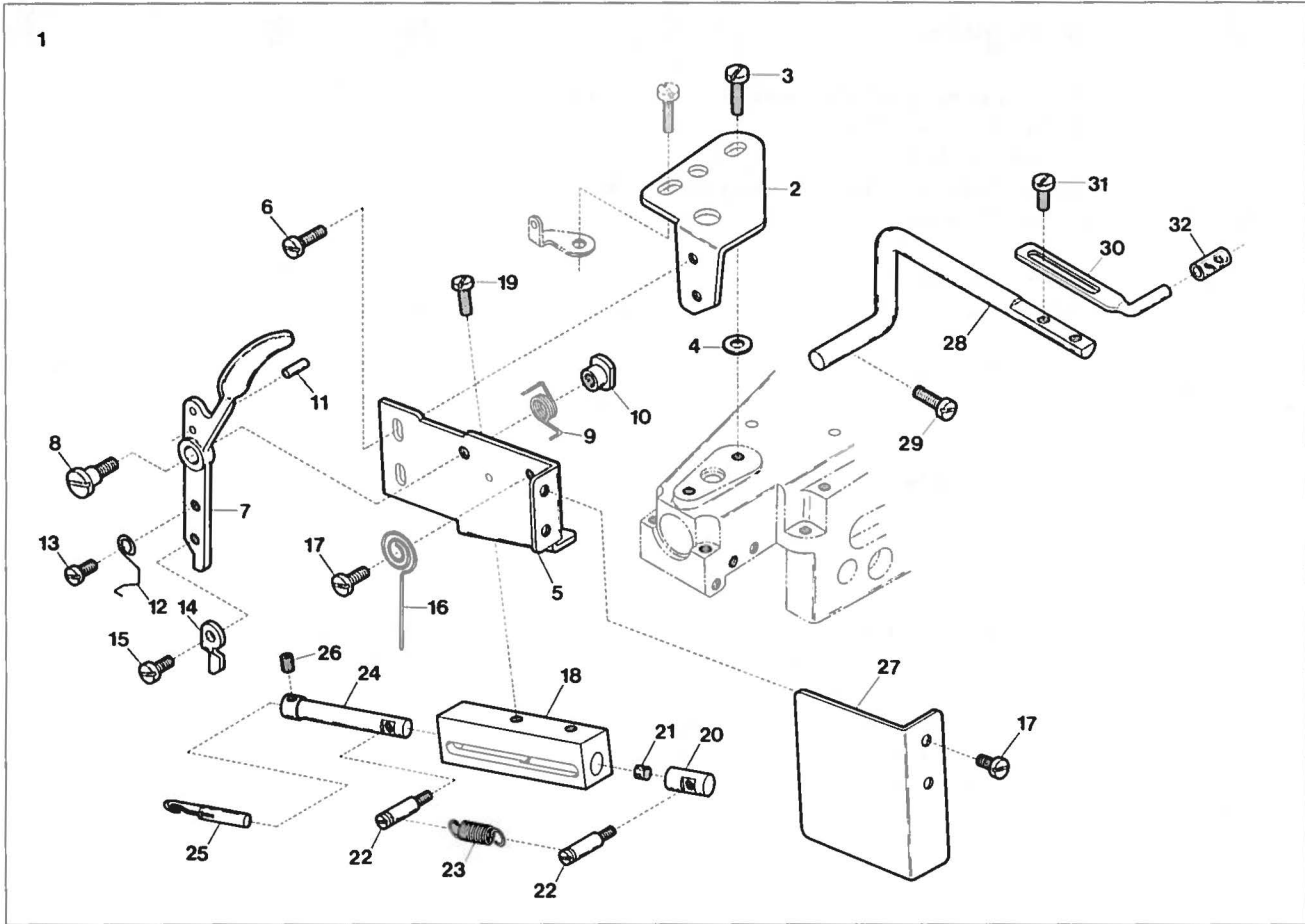

"AT"DEVICE

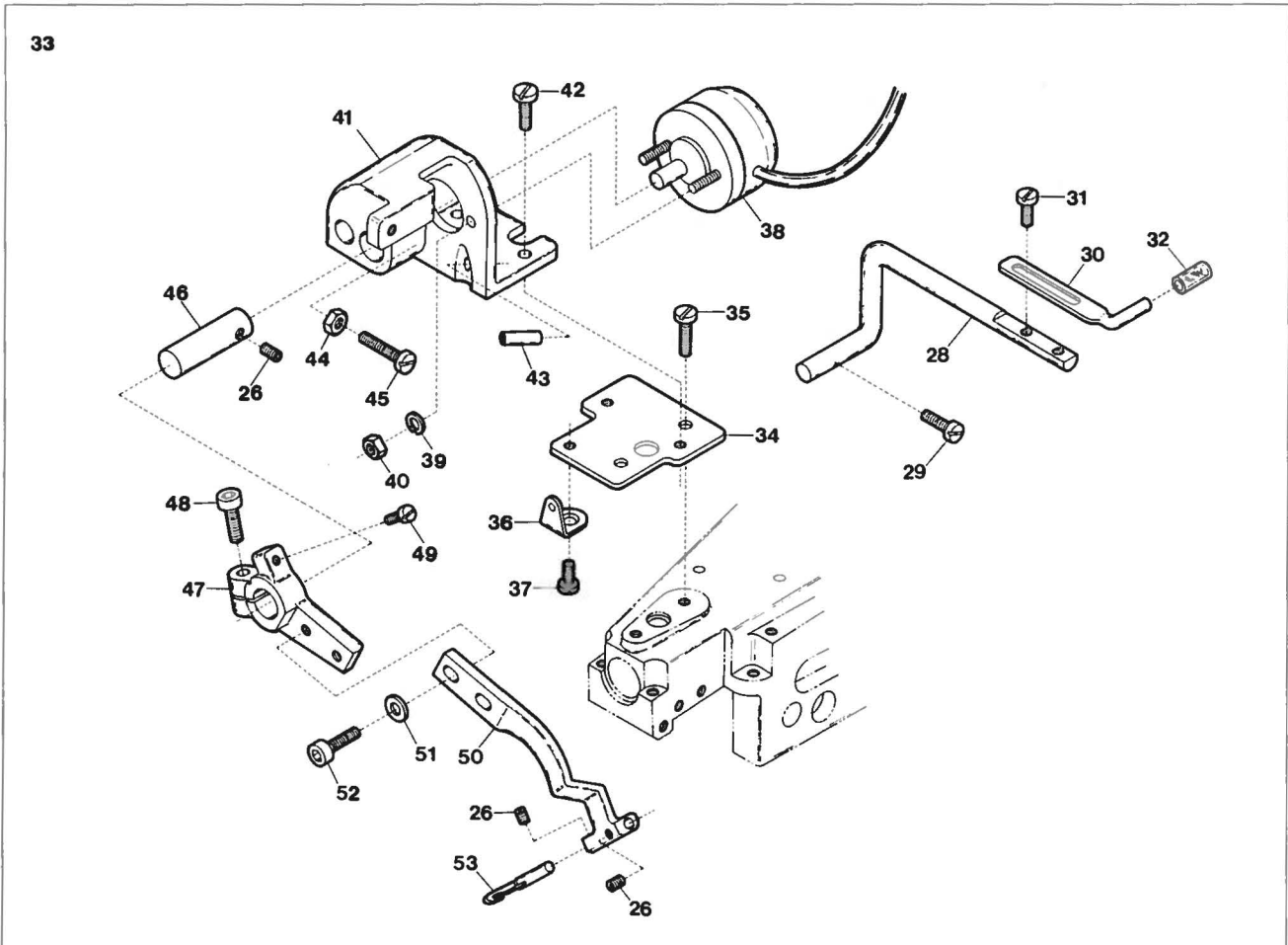

Ref. No.	Parts No.	Description	品名	Amt. Req.
1	81820	"T" Device, Complete Set	"T"装置(組)	1
2	81844	"T" Device Basement	メス装置台取付板	1
3	4471	Screw for 81844	メス装置台取付板止ネジ	1
4	554	Washer for 81844	ワッシャ	1
5	81842	Knife Holder Guide Support	メス装置台	1
6	4353	Screw for 81842	メス装置台止ネジ	2
7	81845	Knife Driving Lever	糸切りレバー	1
8	6050	Screw for 81845	糸切りレバー止ネジ	1
9	81835	Knife Driving Lever Spring	糸切りレバーバネ	1
10	81836	Knife Driving Lever Spring Stopper	糸切りレバーバネ押エ	1
11	81828	Knife Driving Lever Stopper Pin	ストップバビン	1
12	81840	Knife Driving Lever Supplementary Piece Spring	可動片バネ	1
13	1225	Screw for 81840	可動片バネ止ネジ	1
14	81834	Knife Driving Lever Supplementary Piece	可動片	1
15	5518	Screw for 81834	可動片止ネジ	1
16	81839	Knife Holder Return Spring	補助棒バネ	1
17	7006	Screw for 81839, 81843	止ネジ	3
18	81822	Knife Holder Guide	メス棒ガイド	1
19	5000	Screw for 81822	メス棒ガイド止ネジ	2
20	81826	Knife Holder Supplementary Piece	補助棒	1
21	924	Rubber Cushion for 81823	クッション	1
22	81827	Knife Spring Latch	バネ掛ケ	2
23	85940	Knife Spring	メスバネ	1
24	81823	Cutting Knife Holder	メス棒	1
25	81832	Cutting Knife	メス	1
26	3637	Screw for 81832 (for "T" Device)	メス止ネジ	1
26	3637	Screw for 82003, 82012 (for "AT" Device)	止ネジ	3
27	81843	Cutting Mechanism Cover	メス装置カバー	1
28	81847	Synchronizer Positioning Shaft	ポジションナビン取付軸	1
29	4554	Screw for 81847	ポジションナビン取付軸止ネジ	1
30	81846	Synchronizer Positioning Pin	ポジションナビン	1
31	4317	Screw for 81846	ポジションナビン止ネジ	2
32	81848	Synchronizer Cushion	ポジションナビンクッション	1
33	82000	"AT" Device, Complete Set	"AT"装置(組)	1
34	82001	"AT" Device Basement	ソレノイド台取付板	1
35	5047	Screw for 82001	ソレノイド台取付板止ネジ	2
36	60170	Needle Thread Eyelet	針糸道	1
37	4401	Screw for 60170	針糸道止ネジ	1
38	11990	Solenoid	糸切りソレノイド	1
39	2	Spring Washer for 11990	スプリングワッシャ	2
40	12	Nut for 11990	ナット	2
41	82002	Solenoid Support	ソレノイド台	1
42	5506	Screw for 82002	ソレノイド台止ネジ	2
43	32963	Thread Pipe	糸道パイプ	1
44	334	Lock Nut for 4445	ロックナット	1
45	4445	Adjusting Screw for 82004	メスレバー台調節ネジ	1
46	82003	Solenoid Shaft	ソレノイド軸	1
47	82004	Cutting Knife Lever Holder	メスレバー台	1
48	5650	Screw for 82004	メスレバー台止ネジ	1
49	4404	Stopper Screw for 82004	ストップバネネジ	1
50	82005	Cutting Knife Lever	メスレバー	1
51	532	Washer for 82005	ワッシャ	2
52	5037	Screw for 82005	メスレバー止ネジ	2
53	82012	Cutting Knife	メス	1

"AL2" DEVICE

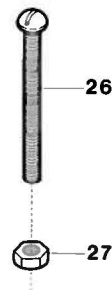
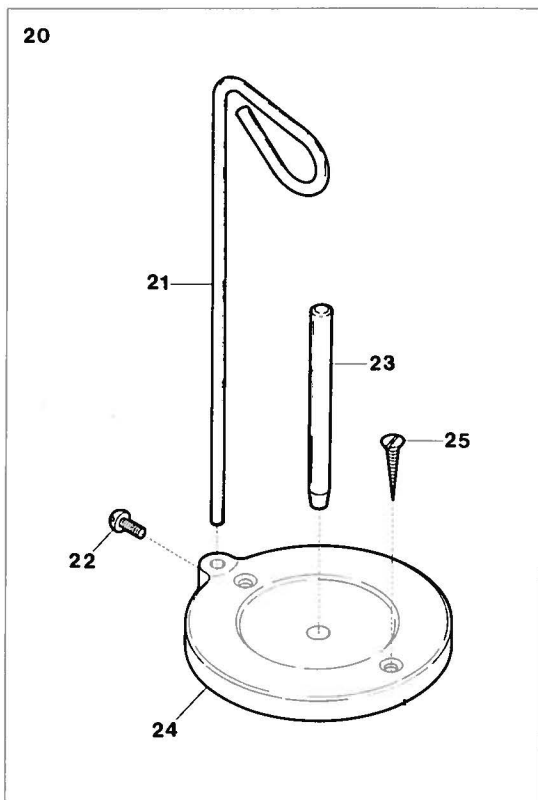
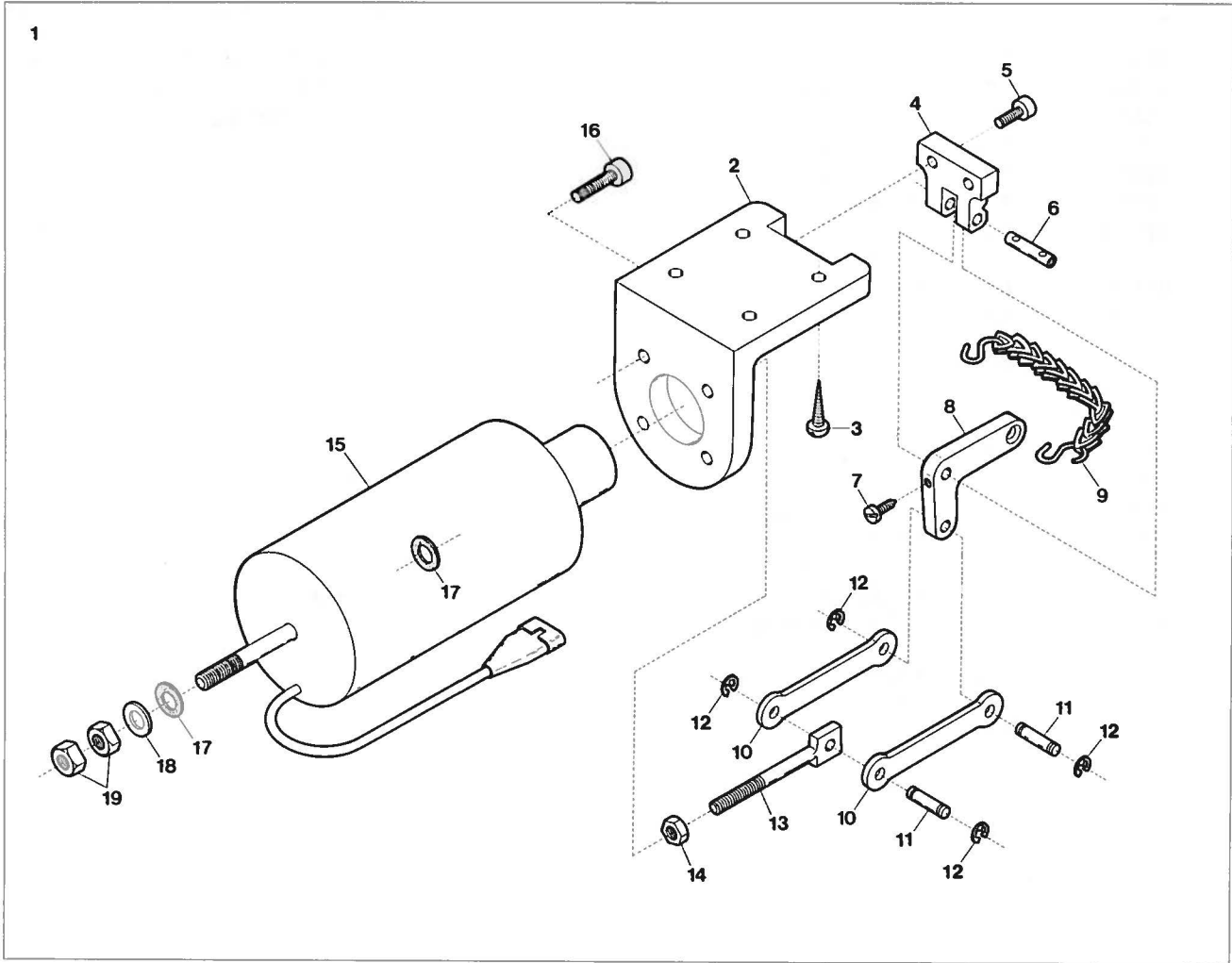

Ref. No.	Parts No.	Description	品名	Amt. Req.
1	95393	"AL2" Device, Complete Set	"AL2"装置(組)	1
2	94479	Presser Foot Lowering Solenoid Support	押エ下ゲソレノイド台	1
3		Wood Screw for 94479	木ネジ	4
4	95398	Presser Foot Lowering Lever Bracket	押エ下ゲレバーブラケット	1
5	5550	Screw for 95398	押エ下ゲレバーブラケット止ネジ	2
6	32784	Presser Foot Lowering Lever Pin	押エ下ゲレバーピン	1
7	9322	Screw for 32784	押エ下ゲレバーピン止ネジ	1
8	95397	Presser Foot Lowering Lever	押エ下ゲレバー	1
9	37912	Chain	チェーン	1
10	95395	Presser Foot Lowering Connecting Link	押エ下ゲリンク	2
11	95396	Presser Foot Lowering Connecting Link Pin	押エ下ゲリンクピン	2
12	33024	Retaining Ring for 95396	ストップリング	4
13	95394	Presser Foot Lowering Connecting Rod	押エ下ゲ連結桿	1
14	306	Nut for 95394	ナット	1
15	11733	Presser Foot Lowering Solenoid Unit	押エ下ゲソレノイド(組)	1
16	5520	Screw for 11733	押エ下ゲソレノイド(組)止ネジ	4
17	588	Anti-shock Rubber for 11733	ソレノイド緩衝ゴム	2
18	555	Washer for 11733	ワッシャー	1
19	9	Nut for 11733	ナット	2
20	80910	Thread Stand, Complete Set	糸立台(組)	1
21	80162	Thread Hanger	糸掛ケ棒	1
22	5147	Screw for 80162	糸掛ケ棒止ネジ	1
23	80163	Spool Pin	糸立棒	1
24	80161	Thread Stand	糸立台	1
25	5148	Screw for 80161	糸立台止ネジ	2
26	5161	Bolt for Machine Frame	ボルト	3
27	362	Nut for Machine Frame	ナット	3

CM-251 Class List of Main Spare Parts (主要部品リスト)

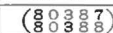
Main Parts Models	Presser Foot Plate, C. Set	Presser Foot Plate	Cloth Retainer	Cloth Guide	Presser Foot (Right) C. Set	Presser Foot (Left) C. Set	Presser Foot (Right)	Presser Foot (Left)	Feed Dog	Differential Feed Dog	Ridge Forming Plate	Looper
	押工受け(組)	押工受け	爪	爪下案内	押工右(組)	押工左(組)	押工右	押工左	送り	差動送り	突上げ板	ルーバ
CM-251	80290	80291	81352	81354	80398	80399	80395	80396	80510	————	81609	80413
252	81345	"	80352	80360	"	"	"	"	"	————	80617	"
255	81364	"	81366	81354	"	"	"	"	"	————	81629	"
256	81347	81348	81352	"	————	81299	————	81303	"	————	81603	"
257	81397	81398	81372	81375	81297	81298	81308	81307	"	————	81644	"
258	81680	"	81674	"	"	"	"	"	"	————	"	"
259	81380	81381	81352	81354	(81317)	————	————	————	81506	————	81645	"
260	81979	80291	81981	"	81971	81970	81966	81967	80510	————	81982	"
261	80680	"	81424	80360	80398	80399	80395	80396	"	————	80678	"
262	80389	80383	()	80397	"	"	"	"	80373	————	80627	"
263	"	"	(")	"	80440	80441	80433	80434	80431	80429	"	"
265	81979	"	81981	"	81971	81970	81966	81967	80510	————	81982	"
270	81410	81411	81352	81354	(81336)	————	————	————	81502	————	81613	"

※押工右(組)欄の()内は、押工右(組)と押工左(組)とが一体になったものです。

※爪欄の()は、上段が爪(右)、下段が爪(左)を示します。

CM-251

INDEX

Parts No.	Page No.	Ref. No.	Weight (g)
2	21	39	0.1
9	22	19	1
12	21	40	0.3
120	8	2	—
182	2	2	4.3
239	5	36	0.9
255	7	24	3.8
306	22	14	1.3
322	3	35	0.3
329	12	34	0.5
334	21	44	0.6
338	7	28	1.1
339	4	13	0.5
339	5	28	0.5
339	12	4	0.5
339	13	28	0.5
339	14	43	0.5
339	15	25	0.5
339	16	44	0.5
339	17	44	0.5
339	19	14	0.5
347	7	18	0.95
354	8	14	—
355	7	21	0.85
355	20	35	0.85
356	20	34	0.8
362	22	27	—
364	2	9	0.87
366	18	36	—
371	7	40	1.8
532	2	14	0.3
532	21	51	0.3
535	8	10	0.78
540	11	19	0.8
552	9	25	0.15
553	7	20	0.3
553	20	42	0.3
554	19	19	0.73
554	19	23	0.73
554	21	4	0.73
555	22	18	2
559	1	3	0.47
571	7	39	1
579	20	36	0.3
580	12	38	3.05
588	22	17	0.2
608	3	18	—
644	3	36	0.8
675	7	8	—
711	13	10	0.05
721	1	13	0.22
721	10	18	0.22

Parts No.	Page No.	Ref. No.	Weight (g)
721	14	18	0.22
721	16	18	0.22
721	17	18	0.22
722	18	33	0.14
724	4	24	1.1
924	21	21	0.02
937	1	11	—
1175	18	27	0.92
1196	1	10	0.5
1196	6	5	0.5
1225	21	13	0.3
1227	13	18	0.3
1228	16	37	0.2
1228	17	37	0.2
1330	2	15	0.6
3312	5	15	0.1
3312	10	39	0.1
3312	11	17	0.1
3312	14	38	0.1
3312	15	15	0.1
3312	16	39	0.1
3312	17	39	0.1
3391	9	6	0.5
3392	8	19	0.5
3393	4	18	0.27
3393	5	17	0.27
3393	7	33	0.27
3393	10	15	0.27
3393	11	15	0.27
3393	14	15	0.27
3393	15	17	0.27
3393	16	15	0.27
3393	17	15	0.27
3393	20	7	0.27
3394	4	12	1
3395	12	27	0.4
3471	3	25	0.37
3472	8	11	0.85
3472	20	8	0.85
3473	6	32	0.75
3474	9	21	2.5
3551	3	9	1.2
3553	7	10	0.75
3554	1	21	0.9
3554	3	4	0.9
3554	6	15	0.9
3555	6	3	0.95
3555	9	9	0.95
3556	1	39	1.4
3556	6	23	1.4
3557	9	8	0.8
3558	6	11	1.1
3559	6	2	0.9

Parts No.	Page No.	Ref. No.	Weight (g)
3559	7	35	0.9
3560	8	6	2.45
3561	7	30	2.8
3563	13	9	0.11
3570	1	35	—
3595	3	2	2.9
3637	21	26	0.1
3638	18	25	0.5
3641	10	13	1.7
3641	14	13	1.7
3641	16	13	1.7
3641	17	13	1.7
3642	1	24	1.3
3643	2	24	2.4
3653	4	8	1
4241	10	34	0.1
4242	9	13	0.2
4243	12	23	0.4
4243	13	16	0.4
4245	5	10	0.18
4245	10	32	0.18
4245	11	10	0.18
4245	4	33	0.18
4245	15	10	0.18
4245	16	33	0.18
4245	17	33	0.18
4246	5	4	0.1
4246	10	26	0.1
4246	11	4	0.1
4246	12	15	0.1
4246	13	22	0.1
4246	14	27	0.1
4246	15	4	0.1
4246	16	28	0.1
4246	17	28	0.1
4280	8	9	2
4281	10	8	0.35
4281	14	8	0.35
4281	16	8	0.35
4281	17	8	0.35
4283	5	13	0.3
4283	10	37	0.3
4283	11	13	0.3
4283	11	26	0.3
4283	12	25	0.3
4283	14	36	0.3
4283	15	13	0.3
4284	12	30	0.2
4300	13	4	0.5
4312	8	16	0.58
4317	5	22	0.5
4317	18	32	0.5
4317	21	31	0.5
4321	12	19	1

INDEX

Parts No.	Page No.	Ref. No.	Weight (g)
4321	20	22	1
4353	18	6	0.9
4353	21	6	0.9
4358	3	33	0.9
4358	18	11	0.9
4389	20	15	1.9
4390	7	16	1.4
4391	3	12	1.4
4391	20	39	1.4
4392	3	11	1.5
4393	5	8	0.2
4393	10	30	0.2
4393	11	8	0.2
4393	12	17	0.2
4393	13	24	0.2
4393	14	31	0.2
4393	15	8	0.2
4393	16	30	0.2
4393	17	30	0.2
4393	19	10	0.2
4394	20	19	1.05
4395	5	6	0.75
4395	10	28	0.75
4395	11	6	0.75
4395	14	29	0.75
4395	15	6	0.75
4397	3	31	0.75
4397	4	23	0.75
4398	5	21	1.6
4399	8	13	0.65
4401	21	37	0.3
4404	21	49	0.25
4406	18	3	1.2
4445	21	45	1.7
4471	2	22	2.9
4471	9	26	2.9
4471	21	3	2.9
4472	19	18	2.7
4472	20	17	2.7
4474	2	19	1.25
4474	11	20	1.25
4475	1	6	1.5
4475	10	17	1.5
4475	12	10	1.5
4475	13	6	1.5
4475	14	17	1.5
4475	16	17	1.5
4475	17	17	1.5
4476	13	13	2.1
4476	19	21	2.1
4481	1	15	2.1
4481	5	24	2.1
4481	19	3	2.1
4551	1	30	4
4552	4	16	2.5

Parts No.	Page No.	Page No.	Weight (g)
4554	3	19	2.3
4554	8	17	2.3
4554	21	29	2.3
4555	1	32	2.4
4641	1	17	9
4642	5	18	3.2
5000	21	19	0.62
5028	18	15	2.6
5033	19	5	0.47
5037	21	52	1.08
5047	7	23	1.1
5047	21	35	1.1
5061	6	17	2.5
5147	22	22	2
5148	22	25	—
5161	22	26	—
5328	7	2	0.3
5347	1	37	1.3
5431	7	7	0.35
5431	20	28	0.35
5460	12	36	3.5
5506	21	42	1.5
5510	18	20	3.75
5512	18	28	1.25
5518	21	15	0.5
5520	22	16	5
5531	13	3	0.5
5531	20	30	0.5
5547	9	23	3.25
5549	3	27	4.1
5550	22	5	2.9
5552	20	44	—
5553	3	21	3
5555	4	6	2.7
5557	3	22	2.9
5558	8	21	6.9
5560	12	39	—
5565	4	11	5
5566	1	23	8.6
5650	21	48	2.8
5662	1	26	3.5
5662	4	4	3.5
6031	6	21	2.4
6032	20	3	2.4
6033	12	6	—
6033	14	45	—
6033	15	27	—
6035	3	37	1.3
6047	4	14	3
6048	6	25	1.2
6050	21	8	3.4
6051	5	30	7.6
6051	11	33	7.6

Parts No.	Page No.	Ref. No.	Weight (g)
6051	13	30	7.6
6051	14	49	7.6
6051	15	31	7.6
6051	16	46	7.6
6051	17	46	7.6
6051	19	16	7.6
6052	20	33	7.3
6056	13	27	6.5
6056	19	13	6.5
6147	1	4	2.3
6222	7	6	0.2
6239	11	31	1.8
6242	7	17	5.5
6339	5	27	1.8
6339	12	3	1.8
6339	14	42	1.8
6339	15	24	1.8
6339	16	43	1.8
6339	17	43	1.8
6433	13	14	2.3
6435	12	20	4.1
6520	7	3	—
6560	2	8	—
6637	20	26	0.76
6638	5	35	0.8
6639	7	27	4.8
6651	7	25	1.5
6855	7	12	0.17
6869	1	8	14.8
6892	7	34	10.2
6900	7	11	—
7006	21	17	0.7
7420	5	20	—
7616	7	14	0.36
7621	18	8	0.5
8047	6	14	0.45
8047	10	10	0.45
8047	14	10	0.45
8047	16	10	0.45
8047	17	10	0.45
8145	18	18	0.35
9322	22	7	0.6
11733	22	15	—
11990	21	38	13.7
20072	1	18	0.5
20126	7	3	1.5
31111	2	7	5
32784	22	6	3.35
32963	21	43	1.1
33024	22	12	0.1
33764	2	13	1.5

INDEX

Parts No.	Page No.	Ref. No.	Weight (g)
37912	22	9	—
60170	21	36	2.3
80005	6	19	65
80115	1	14	27.6
80118	1	33	—
80121	1	22	407.5
80122	1	19	88
80123	1	20	11.8
80123	3	3	11.8
80124	1	16	—
80125	1	25	—
80126	1	27	15.5
80127	1	28	13.5
80128	1	29	9
80131	2	16	1
80132	2	18	0.2
80135	2	30	2.4
80136	2	20	3.4
80140	1	1	—
80144	1	5	94
80145	3	1	750
80146	1	9	7.6
80153	1	42	—
80154	1	40	—
80155	1	41	—
80161	22	24	—
80162	22	21	—
80163	22	23	—
80200	2	23	286.5
80202	3	5	302
80204	2	25	169
80208	3	17	54.2
80209	3	7	147.6
80210	3	10	66.6
80211	3	8	61.2
80215	3	14	0.2
80215	8	3	0.2
80215	9	18	0.2
80216	3	13	0.2
80217	3	16	19.4
80218	3	20	46
80219	3	23	129
80220	2	26	43.2
80221	2	27	39.3
80222	3	24	9.6
80224	3	28	0.05
80224	12	21	0.05
80226	3	30	3
80290	5	1	—
80291	5	2	49
80291	10	24	49
80291	11	2	49
80291	14	25	49

Parts No.	Page No.	Ref. No.	Weight (g)
80291	15	2	49
80293	1	31	—
80295	1	7	174
80297	1	34	—
80299	4	2	—
80300	4	1	450
80301	4	3	250
80302	4	5	200
80303	4	7	94.2
80304	4	21	155.5
80305	2	29	22
80306	4	9	6.5
80308	4	22	9.6
80309	4	25	3.9
80309	6	26	3.9
80310	4	10	56
80311	4	19	40
80312	4	15	26.4
80313	4	20	104.5
80314	4	17	3.5
80316	5	23	10.3
80317	5	26	—
80318	5	32	—
80320	5	33	25
80320	17	49	25
80321	5	29	—
80321	16	45	—
80322	5	31	—
80323	5	25	—
80325	4	26	3.9
80325	6	27	3.9
80328	3	26	38
80346	14	48	—
80346	15	30	—
80346	16	49	—
80347	17	45	—
80348	5	34	1.5
80352	10	31	1.2
80353	10	33	0.2
80354	5	14	2.1
80354	10	38	2.1
80354	11	16	2.1
80354	14	37	2.1
80354	15	14	2.1
80354	16	38	2.1
80354	17	38	2.1
80355	5	11	0.2
80355	10	35	0.2
80355	11	11	0.2
80355	14	34	0.2
80355	15	11	0.2
80356	5	16	3.2
80356	10	40	3.2
80356	11	14	3.2
80356	14	39	3.2

Parts No.	Page No.	Ref. No.	Weight (g)
80356	15	16	3.2
80356	16	40	3.2
80356	17	40	3.2
80357	5	5	0.9
80357	10	27	0.9
80357	11	5	0.9
80357	14	28	0.9
80357	15	5	0.9
80358	5	7	0.2
80358	10	29	0.2
80358	11	7	0.2
80358	12	16	0.2
80358	13	23	0.2
80358	14	30	0.2
80358	15	7	0.2
80358	16	29	0.2
80358	17	29	0.2
80360	10	36	0.7
80360	15	12	0.7
80373	16	24	15
80381	5	19	9
80382	16	27	—
80382	17	27	—
80383	16	26	49
80383	17	26	49
80385	16	35	6.1
80385	17	35	6.1
80386	16	36	0.4
80386	17	36	0.4
80387	16	31	3.6
80387	17	31	3.6
80388	16	32	2.4
80388	17	32	2.4
80389	16	25	—
80389	17	25	—
80391	3	34	—
80392	3	32	—
80393	2	21	1.6
80395	16	48	—
80396	16	42	—
80397	16	34	0.7
80397	17	34	0.7
80398	16	47	34
80399	16	41	35
80400	8	4	90.8
80401	8	5	76.3
80402	8	7	9.3
80403	8	1	11.8
80404	8	8	11.1
80405	8	10	5.6
80406	8	12	16.2
80407	8	23	29.2
80408	8	18	9.1
80411	8	20	36.8

INDEX

Parts No.	Page No.	Ref. No.	Weight (g)
80412	8	22	18.2
80413	8	24	2.3
80415	8	15	28.4
80418	5	3	—
80418	10	25	—
80418	11	3	—
80418	12	14	—
80418	13	21	—
80418	14	26	—
80418	15	3	—
80418	16	7	—
80418	17	7	—
80419	18	2	78
80421	18	30	37
80422	18	35	16
80423	18	34	8
80424	18	29	5.6
80425	18	14	—
80426	18	19	18
80427	18	21	25
80428	18	24	6.3
80429	18	26	5
80430	18	22	17.5
80431	18	23	7.8
80432	18	5	5.8
80433	17	48	—
80434	17	42	—
80435	18	37	1
80438	18	39	16
80439	18	38	20
80440	17	47	35
80441	17	41	34
80442	18	13	31
80443	18	4	0.05
80444	18	31	2.8
80450	18	1	—
80500	9	10	—
80501	9	11	82
80502	9	12	27
80503	9	15	0.25
80503	10	20	0.25
80503	14	20	0.25
80503	16	20	0.25
80503	17	20	0.25
80504	9	14	0.2
80505	9	16	—
80506	9	19	18
80507	9	20	10.4
80508	9	22	2.5
80510	9	24	13.2
80511	2	28	10
80520	9	1	16
80521	9	2	5.4
80522	9	5	4
80523	9	3	0.3

Parts No.	Page No.	Ref. No.	Weight (g)
80524	9	4	6.3
80531	9	7	—
80601	10	1	55
80601	14	1	55
80601	16	1	55
80601	17	1	55
80602	10	2	30.9
80602	14	2	30.9
80602	16	2	30.9
80602	17	2	30.9
80603	10	4	250
80603	14	4	250
80603	16	4	250
80603	17	4	250
80605	6	9	8.2
80606	6	12	61.6
80609	7	19	6.8
80609	20	37	6.8
80610	7	22	17.4
80611	7	36	71
80612	7	31	125
80613	7	29	6.6
80614	7	26	7.5
80615	7	32	7.8
80616	7	37	2.6
80617	10	41	7.1
80618	7	15	21
80619	6	6	1
80623	10	6	34.8
80623	14	6	34.8
80623	16	6	34.8
80623	17	6	34.8
80624	10	3	1.2
80624	14	3	1.2
80624	16	3	1.2
80624	17	3	1.2
80627	16	23	9
80627	17	23	9
80635	10	14	4.2
80635	14	14	4.2
80635	16	14	4.2
80635	17	14	4.2
80636	10	12	37.6
80636	14	12	37.6
80636	16	12	37.6
80636	17	12	37.6
80640	10	16	19.5
80640	14	16	19.5
80640	16	16	19.5
80640	17	16	19.5
80643	10	22	20.3
80643	14	22	20.3
80643	16	22	20.3
80643	17	22	20.3
80644	10	19	21.6

Parts No.	Page No.	Ref. No.	Weight (g)
80644	14	19	21.6
80644	16	19	21.6
80644	17	19	21.6
80645	10	9	13.3
80645	14	9	13.3
80645	16	9	13.3
80645	17	9	13.3
80646	10	7	17.2
80646	14	7	17.2
80646	16	7	17.2
80646	17	7	17.2
80647	10	11	70.4
80647	14	11	70.4
80647	16	11	70.4
80647	17	11	70.4
80651	6	16	242
80652	6	20	2
80655	6	13	12.9
80656	6	18	45.4
80657	6	10	76.9
80658	6	22	19
80659	6	24	3.3
80661	6	31	35
80662	6	28	8.9
80663	6	29	17.6
80664	6	30	2.4
80665	6	33	2.1
80673	7	5	3
80675	17	21	0.15
80675	10	21	0.15
80675	14	21	0.15
80675	16	21	0.15
80678	15	18	9.7
80680	15	1	69.5
80681	10	5	0.05
80681	14	5	0.05
80681	16	5	0.05
80681	17	5	0.05
80691	7	1	6
80692	7	13	20
80693	7	4	26
80694	7	9	14
80701	3	6	61.4
80740	2	1	—
80741	2	11	24
80742	2	12	0.9
80743	2	6	1.4
80744	2	5	0.5
80745	2	10	7
80746	1	2	—
80910	22	20	—
81102	11	28	60
81105	11	27	—
81111	19	20	72
81112	19	17	75

INDEX

Parts No.	Page No.	Ref. No.	Weight (g)
81116	12	9	51
81117	12	37	—
81118	12	35	—
81121	13	1	2.5kg
81130	12	11	—
81180	19	1	—
81297	12	7	35
81298	12	1	35
81299	11	29	—
81300	11	32	—
81301	11	36	102.5
81303	11	30	17.5
81304	11	34	2
81305	12	5	20
81307	12	2	10.7
81308	12	8	12.8
81312	19	2	15
81315	13	25	21.5
81315	19	11	21.5
81316	13	29	20.9
81316	19	15	20.9
81317	13	26	22
81336	19	12	20
81345	10	23	—
81347	11	22	52
81348	11	23	—
81352	5	9	1.3
81352	11	24	1.3
81353	11	25	3
81354	5	12	0.7
81354	11	12	0.7
81354	14	35	0.7
81354	15	21	0.7
81356	11	1	—
81366	11	9	1.7
81372	12	18	8
81374	12	26	7
81375	12	24	1.2
81380	13	19	48
81381	13	20	47.3
81397	12	12	—
81398	12	13	56.3
81410	19	7	53
81411	19	8	—
81412	19	9	—
81424	15	9	1.4
81500	19	4	185
81502	19	6	16
81506	13	31	13
81601	6	1	67
81602	6	4	6.4
81603	11	35	7

Parts No.	Page No.	Ref. No.	Weight (g)
81607	1	38	47.6
81608	1	36	17
81609	7	38	5.7
81610	20	1	72
81613	20	2	12
81614	20	5	7
81615	20	4	8.5
81616	20	6	4
81617	6	8	250
81629	11	21	10
81640	12	28	—
81641	12	33	8
81642	12	31	3.4
81643	12	32	0.5
81644	12	29	1.8
81645	13	32	5.7
81670	12	47	2.4
81671	12	43	3
81672	12	46	1.2
81673	12	45	2
81674	12	41	9
81675	12	44	0.5
81676	12	42	—
81680	12	40	—
81701	20	16	712
81702	20	9	7.5
81703	20	10-1	5
81704	20	13-1	4.5
81705	20	14-1	4.5
81709	20	41	15.5
81710	20	38	18
81711	20	43	86
81714	20	40	16
81717	20	32	43.7
81718	20	31	4
81719	20	21	14
81720	20	24	14
81721	20	23	—
81722	20	20	0.38
81723	20	29-1	8.6
81724	20	18	7
81725	20	25	7
81726	20	11-1	0.2
81727	20	12-1	3
81728	20	27-1	6.2
81731	20	10-2	3
81732	20	13-2	4.9
81733	20	14-2	4.9
81734	20	29-2	9.2
81735	20	11-2	0.25
81736	20	12-2	3
81737	20	27-2	6.8
81752	18	12	15
81758	18	17	—

Parts No.	Page No.	Ref. No.	Weight (g)
81801	13	2	19.5
81802	13	5	12.5
81806	13	11	7.5
81807	13	17	1.25
81808	13	8	1.7
81809	13	12	6
81810	12	22	0.2
81810	13	15	0.2
81820	21	1	—
81822	21	18	53
81823	21	24	10
81826	21	20	4
81827	21	22	1.4
81828	21	11	0.25
81832	21	25	—
81834	21	14	—
81835	21	9	1
81836	21	10	1.6
81839	21	16	0.5
81840	21	12	0.01
81842	21	5	51
81843	21	27	14.4
81844	21	2	39
81845	21	7	15
81846	21	30	4
81847	21	28	—
81848	21	32	—
81877	18	16	—
81889	18	9	4.4
81890	18	7	5.8
81901	11	18	14
81925	13	7	25
81966	14	47	—
81966	15	29	—
81967	14	41	—
81967	15	23	—
81969	14	44	—
81969	15	26	—
81970	14	40	—
81970	15	22	—
81971	14	46	—
81971	15	28	—
81976	19	22	17
81979	14	24	—
81979	15	19	—
81981	14	32	1.5
81981	15	20	1.5
81982	14	23	—
81982	15	32	—
82000	21	33	—
82001	21	34	25
82002	21	41	55
82003	21	46	20
82004	21	47	11.5

INDEX

<u>Parts No.</u>	<u>Page No.</u>	<u>Ref. No.</u>	<u>Weight (g)</u>
82005	21	50	10
82012	21	53	1.2
85277	2	4	0.7
85940	21	23	0.5
94479	22	2	1.62kg
95393	22	1	—
95394	22	13	17.5
95395	22	10	8.5
95396	22	11	2.8
95397	22	8	46.5
95398	22	4	85

<u>Parts No.</u>	<u>Page No.</u>	<u>Ref. No.</u>	<u>Weight (g)</u>
------------------	-----------------	-----------------	-------------------

<u>Parts No.</u>	<u>Page No.</u>	<u>Ref. No.</u>	<u>Weight (g)</u>
------------------	-----------------	-----------------	-------------------

